

INSTALLATION, OPERATION & MAINTENANCE MANUAL OF SMILE - G3 - S3.6 / S5 / B5



DISCLAIMER

Copyright © AlphaESS Co., Ltd. 2022. All rights reserved.

No part of this document may be reproduced or transmitted in any form or by any means without prior written consent of AlphaESS Co., Ltd.

The material furnished in this document is believed to be accurate and reliable. The information and recommendations in this document do not constitute commitments or warranties in the form of assignments. The information in this document is subject to change without notice. You may refer to the Alpha Cloud Platform (<https://cloud.alphaess.com>) for the most updated version.

All company and brand products and service names are trademarks or registered trademarks of their respective holders.

COPYRIGHT STATEMENT

This manual is under the copyright of Alpha ESS Co., Ltd. with all rights reserved. Please keep the manual properly and operate in strict accordance with all safety and operating instructions in this manual. Please do not operate the product before reading through the manual.

CONTENT

DISCLAIMER 1

COPYRIGHT STATEMENT..... 2

1. INTRODUCTION 7

1.1. Content and Structure of this Document 7

1.2. Target Group 7

1.3. Levels of Warning Messages 8

1.4. Definition of Abbreviations and Nouns 9

2. Safety 10

2.1. Intended Use 10

2.2. Safety Instructions for Battery 11

 2.2.1. General Safety Precautions 11

 2.2.2. Response to Emergency Situations 11

2.3. Important Safety Instructions 12

2.4. Symbols explanation 16

3. Product Introduction and Application Scenarios 18

3.1. Nomenclature introduction 18

3.2. System introduction 19

3.3. Product Description 19

 3.3.1. Inverter Electrical Interface Introduction 19

 3.3.2. Inverter Display Interface Introduction 21

 3.3.3. Battery Introduction 23

3.4. Application Scenarios 24

 3.4.1. DC-coupled Storage System 24

 3.4.2. AC-coupled Storage System 25

 3.4.3. Hybrid-coupled Storage System 25

4. Storage and Transport	26
4.1. Storage	26
4.1.1. Inverter Storage.....	26
4.1.2. Battery Storage.....	26
4.2. Transport.....	27
5. Mounting	28
5.1. Checking the Outer Packing.....	28
5.2. Scope of Delivery	28
5.3. Requirements for Mounting.....	30
5.3.1. Basic Requirements	30
5.3.2. Mounting Environment Requirements.....	30
5.3.3. Mounting Structure Requirements.....	31
5.3.4. Mounting Angle and Stack Requirement.....	31
5.3.5. Mounting Space Requirements	32
5.4. Preparing Tools and Instruments	33
5.5. Mounting the Product.....	34
5.5.1. Mounting the Battery	34
5.5.2. Mounting the Inverter	36
5.5.3. Mounting the WiFi Module	37
6. Electrical Connection.....	38
6.1. Cable Requirements for Connection.....	39
6.2. Connecting Additional Grounding.....	40
6.3. AC Connection	41
6.3.1. Requirements for the AC Connection.....	41
6.3.2. Grid and Backup Connection.....	42
6.3.3. CT Connection & Electricity Meter Connection	43
6.3.4. CT Connection	43
6.3.5. Chint Meter Connection	45
6.3.6. Configuring the Chint Meter	47
6.4. PV Connection.....	50

6.5. Electrical Connection Between the Inverter and Battery Packs	51
6.5.1. Electrical Connection Between the Inverter and Smile-Bat series	51
6.5.2. AUX/LAN/PV-CT/DRM、RRCR/GRID-CT、Meter/RS485/BMS Connection	53
6.6. Mounting the Battery and Inverter decorative.....	55
7. Installer Account Register and Install New System.....	56
7.1. Register on APP	56
7.1.1. Download and Install APP	56
7.1.2. Register as Installer Account.....	56
7.1.3. Overview of Functions for Installer Account.....	57
7.1.4. Install New System	58
7.2. Register on AlphaCoud	60
7.2.1. Register as Installer Account.....	60
7.2.2. Install New System	61
8. Powering On and Off the System	63
8.1. Powering on the System	63
8.2. Powering off the System	63
9. COMMISSIONING	64
9.1. Checking Before Power-On	64
9.2. Powering on the System and Install the Battery and inverter plastic decorative.....	64
9.3. WiFi Module Configuration and Parameter Settings.....	66
9.3.1. WiFi Configuration	66
9.3.2. Direct Commissioning on WiFi configuration	71
9.4. Installing New System and Settings on the APP	74
9.4.1. Download and Install the APP.....	74
9.4.2. Register as an Installer	74
9.4.3. Install New System	74
9.5. Check the Running State On-line.....	76
9.5.1. Check the Charging Function of the Product.....	76

9.5.2. Check the PV Generation and Discharging Function of the Product.....	78
9.5.3. Check the UPS State of the Product.....	79
9.6. Instruct the End User to Install the APP	79
10. Maintenance and Troubleshooting	80
10.1. Routine Maintenance.....	80
10.2. Troubleshooting.....	81
10.2.1. Inverter Protection Description.....	87
10.2.2. Battery Protection Description.....	91
10.2.3. Battery Error Description	92
11. Uninstallation & Return	94
11.1. Removing the Product	94
11.2. Packing the Product	94
11.3. Disposing of the Product.....	94
12. Specification	95
12.1. Datasheet of Inverter SMILE-G3-INV	95
12.2. Datasheet of Battery	100
13. Appendix 2: Regional Application Standard	104

1. INTRODUCTION

1.1. Content and Structure of this Document

This document is valid for product of SMILE-G3 system which include inverter SMILE-G3-INV and battery Smile-G3-BAT.

This document describes the mounting, installation, commissioning, configuration, operation, troubleshooting and decommissioning of the product as well as the operation of the product user interface.

Observe all documentation that accompanies the product, keep them in a convenient place and available at all times.

Illustrations in this document are reduced to the essential information and may deviate from the real product.

1.2. Target Group

This document is intended for qualified persons and end users. Only qualified persons are allowed to perform the operations marked with a warning symbol in this document. Tasks that do not require any specific qualifications will not be marked and can be performed by the end user. Qualified persons must have.

- Knowledge of working principle of inverters.
- Knowledge of how to deal with the dangers and risks associated with installing and using electrical devices, batteries and systems.
- Knowledge of the installation and commissioning of electrical devices and systems.
- Knowledge of the applicable standards and directives.
- Understood and complied with this document, including all safety precautions.
- Understood and complied with the documents of the battery manufacturer, including all safety precautions.

1.3. Levels of Warning Messages

The following levels of warning messages may occur when handling the product

 **DANGER**

DANGER indicates a hazardous situation which, if not avoided, will result in death or serious injury.

 **WARNING**

WARNING indicates a hazardous situation which, if not avoided, could result in death or serious injury.

 **CAUTION**

CAUTION indicates a hazardous situation which, if not avoided, could result in minor or moderate injury.

 **NOTICE**

NOTICE indicates a situation which, if not avoided, can result in property damage.

INFORMATION provides tips which are valuable for the optimal installation and operation of the product.

1.4. Definition of Abbreviations and Nouns**A**

AC alternating current

APP application

AUX auxiliary

B

BAT battery

BMS battery management system

D

DC direct current

E

EMS energy management system

I

INV inverter

P

PV photovoltaic

2. Safety

2.1. Intended Use

The inverter, battery packs and the electricity meters make up a system for optimization of self-consumption for a household. The inverter can achieve bidirectional transfer between AC current and DC current. The battery pack is used for the energy storage.

The SMILE-G3 system is suitable for indoor and outdoor installation.

The SMILE-G3-INV must only be operated with PV arrays of protection class II in accordance with IEC 61730, application class A. The PV modules must be compatible with this product.

PV modules with a high capacity to ground must only be used if their coupling capacity does not exceed 1.0 μF .

All components must operate in a scenario suitable for their operation.

Be sure to use this product in accordance with the information provided in the accompanying documents and local applicable standards and directives. Any other operation may cause personal injury or property damage.

Alterations to the product, e.g. changes or modifications, are only permitted with the express written permission of AlphaESS. Unauthorized alterations will void guarantee and warranty claims. AlphaESS shall not be held liable for any damage caused by such changes.

Any use of the product other than that described in the Intended Use section does not qualify as appropriate.

The enclosed documentation is an integral part of this product. Keep the documentation in a convenient place for future reference and comply with all instructions contained therein.

The type label must remain permanently attached to the product.

2.2. Safety Instructions for Battery

2.2.1. General Safety Precautions

- Overvoltage or wrong wiring can damage the battery pack and cause deflagration, which can be extremely dangerous.
- All types of breakdown of the battery may lead to a leakage of electrolyte or flammable gas.
- Battery pack is not user-serviceable. There is high voltage in the device.
- Read the label with Warning Symbols and Precautions, which is on the right side of the battery pack.
- Do not connect any AC conductors or PV conductors directly to the battery pack which should be only connected to the inverter.
- Do not charge or discharge damaged battery.
- Do not damage the battery pack in such ways as dropping, deforming, impacting, cutting or penetrating with a sharp object. It may cause a leakage of electrolyte or fire.
- Do not expose battery to open flame.

2.2.2. Response to Emergency Situations

The battery pack is composed of multiple batteries and designed to prevent the danger caused by malfunction.

- If the user touches the inner material of the battery cells due to damage to the shell, the following actions are recommended.
 1. Inhalation: Leave the contaminated area immediately and seek medical attention.
 2. Eye injuries: Rinse eyes with running water for 15 minutes and seek medical attention.
 3. Skin injuries: Wash the contacted area with soap thoroughly and seek medical attention.
 4. Ingestion: Induce vomiting and seek medical attention.

If a fire breaks out in the place where the battery pack is installed, perform the following countermeasures:

- Fire extinguishing media
 1. Respirator is not required during normal operations.
 2. Use FM-200 or CO² extinguisher for battery fire.
 3. Use an ABC fire extinguisher, if the fire is not from battery and not spread to it yet.
- Firefighting instructions
 1. If fire occurs when charging batteries, if it is safe to do so, disconnect the battery pack circuit breaker to shut off the power to charge.

2. If the battery pack is not on fire yet, extinguish the fire before the battery pack catches fire.
3. If the battery pack is on fire, do not try to extinguish but evacuate people immediately.

**WARNING**

There may be a possible explosion when batteries are heated above 150°C. When the battery pack is burning, it leaks poisonous gases. Do not approach.

- Effective ways to deal with accidents
 1. On land: Place damaged battery into a segregated place and call local fire department or service engineer.
 2. In water: Stay out of the water and don't touch anything if any part of the battery, inverter, or wiring is submerged.
 3. Do not use submerged battery again and contact the service engineer.

2.3. Important Safety Instructions

**DANGER**

Danger to life due to electric shock when live components or cables are touched.

There is high voltage in the conductive components or cables of the product. Touching live parts and cables can result in death or lethal injuries due to electric shock.

- Do not touch non-insulated parts or cables.
- Disconnect the product from voltage sources and make sure it cannot be reconnected before working on the inverter or the battery pack.
- After disconnection, wait for 5 minutes until the capacitors have discharged.
- Do not open the product.
- Wear suitable personal protective equipment for all operations on the product.

 **DANGER****Danger to life due to danger voltages on the battery pack.**

There is danger voltage at the pin connector for the power cable. Reaching into the pin connector for the power cable can result in lethal electric shock.

- Do not open the battery pack.
- Do not wipe over the battery pack with a damp cloth.
- Leave the protective caps on the pin connectors for the batteries power connection until the inverter cables are connected to the battery pack.
- Disconnect the system from voltage sources and make sure it cannot be reconnected before working on the inverter or the battery pack.

 **WARNING****Risk of chemical burns from electrolyte or toxic gases.**

During normal operation, no electrolyte would leak from the battery pack and no toxic gases would form. Despite careful construction, if the battery pack is damaged or a fault occurs, it is possible that electrolyte may be leaked or toxic gases may form.

- Store the battery pack in a cool and dry place.
- Do not drop the battery pack or damage it with sharp objects.
- Only set the battery pack down on its back or its bottom.
- Do not open the battery pack.
- Do not install or operate the battery pack in potentially explosive atmosphere or areas of high humidity.
- If moisture has penetrated the battery pack (e.g. due to a damaged housing), do not install or operate the battery pack.
- In case of contact with electrolyte, rinse the affected areas immediately with water and consult a doctor without delay.

 **CAUTION****Risk of burns due to hot heatsink and housing.**

The heatsink and housing can get hot during operation.

During operation, do not touch any parts other than the cover of the inverter.

 **NOTICE****Damage to the inverter due to electrostatic discharge.**

- Touching electronic components can cause damage to or destroy the inverter through electrostatic discharge.
- Ground yourself before touching any component.

 **NOTICE****Damage due to cleaning agents.**

- The use of cleaning agents may cause damage to the product and its components.
- Clean the product and all its components only with a cloth moistened with clear water.

 **DANGER****Danger to life due to electric shock when live components or PV cables are touched.**

When PV panels exposed to sunlight, the PV array generates high DC voltage which presents in the DC conductors. Touching the live DC cables can result in death or lethal injuries due to electric shock.

- Disconnect the inverter from voltage sources and make sure it cannot be reconnected before working on the device.
- Do not touch non-insulated parts or cables.
- Do not disconnect the DC connectors under load.
- Wear suitable personal protective equipment for all work on the inverter.

 **DANGER****Danger to life due to electric shock from touching an ungrounded PV module or array frame.**

- Touching ungrounded PV modules or array frames can result in death or lethal injuries due to electric shock.
- Connect and ground the frame of the PV modules, the array frame and the electrically conductive surfaces so that there is continuous conduction.
- Observe the applicable local regulations.











**DANGER****Danger to life due to electric shock when touching live system components in case of a ground fault.**

When a ground fault occurs, parts of the system may still be live. Touching live parts and cables can result in death or lethal injuries due to electric shock.













- Disconnect the product from voltage sources and make sure it cannot be reconnected before working on the device.
- Touch the cables of the PV array on the insulation only.
- Do not touch any parts of the substructure or frame of the PV array.
- Do not connect PV strings with ground faults to the inverter.

2.4. Symbols explanation

Symbols on the type label of the inverter:

Symbol	Explanation
	Beware of a danger zone This symbol indicates that the product must be additionally grounded if additional grounding or equipotential bonding is required at the installation site.
	Beware of electrical voltage The product operates at high voltages.
	Beware of hot surface The product can get hot during operation.
	Danger to life due to high voltages in the inverter, observe a waiting time of 5 minutes. Prior to performing any work on the inverter, dis-connect it from all voltage sources as described in this document.
	WEEE designation Do not dispose of the product together with the household waste but in accordance with the disposal regulations for electronic waste applicable at the installation site.
	Observe the documentation
	CE marking The product complies with the requirements of the applicable EU directives.
	Certified safety The product is TÜV-tested and complies with the requirements of the EU Equipment and Product Safety Act.
	RCM (Regulatory Compliance Mark) The product complies with the requirements of the applicable Australian standards.
	UKCA marking The product complies with the regulations of the applicable laws of England, Wales and Scotland.
	RoHS labeling The product complies with the requirements of the applicable EU directives.

Symbols on the type label and warning label of the battery pack.

Symbol	Explanation
	Beware of a danger zone This symbol indicates that the battery pack must be additionally grounded if additional grounding or equipotential bonding is required at the installation site.
	Risk of chemical burns
	Risk of explosion
	Observe the documentation
	Risk of electrolyte leakage
	CE marking The product complies with the requirements of the applicable EU directives.
	Refer to the instruction for operation
	Use eye protection
	Fire, naked light and smoking prohibited
	No nearing
	Do not dispose of the battery pack together with the household waste but in accordance with the locally applicable disposal regulations for batteries
	Recycling code
UN38.3	Marking for transport of dangerous goods The product passes the certifications of the UN38.3

3. Product Introduction and Application Scenarios

3.1. Nomenclature introduction

SMILE-G3-S5

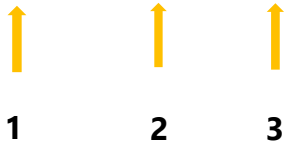

Location	Name	Explanation
1	SMILE	Residential system
2	G3	Generation 3
3	S5 S3.6 B5	5kW Single-phase hybrid inverter 3.6kW Single-phase hybrid inverter 5kW Single-phase battery inverter

Complete designation	Designation in this document
SMILE-G3-S5-INV, SMILE-G3-S3.6-INV, SMILE-G3-B5-INV	Energy storage inverter
SMILE-G3-BAT-10.1P	Battery
SMILE-G3-S5, SMILE-G3-S3.6, SMILE-G3-B5	System/ Energy storage system

Position	Designation
1	Grid Connector
2	Backup Connector
3	Battery+ Power Connector
4	Battery- Power Connector
5	Battery Breaker* of the Inverter
6	Positive and Negative PV connectors, PV 1/ PV2 ***
7	PV Switch***
8	Wi-Fi Port
9	Communication Ports (CAN/RS485,BMS, LAN, Meter/Grid-CT, DRM**, PV-CT, AUX)
10	Inverter LED

*All breakers of the product are switched off when shipped.

**The DRM is only for regions with AS/NZW 4777.2 safety regulations.







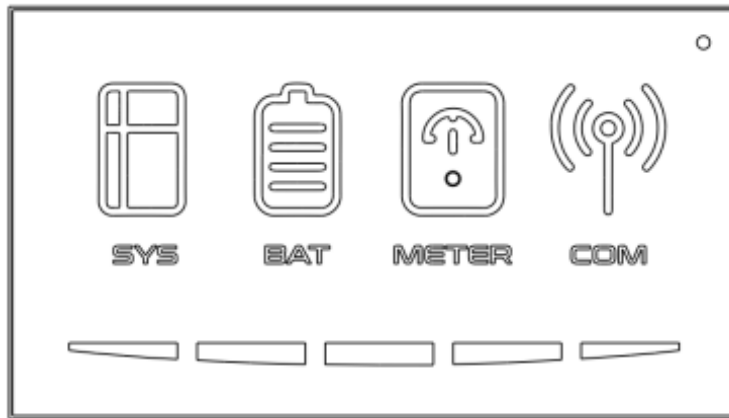

***For product B5, there are no PV switch and PV inputs.

3.3.2. Inverter Display Interface Introduction







LED Display



Five LED indicators and one reset button are provided on the display panel. These LED indicators provide information about the operation status of the system.

Status	Explanation	Status	Explanation
	White light The system works normally		White light The battery pack works normally
	Red light The system is fault		No light Battery is not working normally
	White light Meter communication works normally		White light Disconnect to the server
	No light Meter lost		No light Disconnect to the server

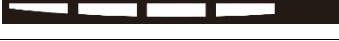
The LED indicators provide information about the SOC operation status of the battery pack.

LED Indicator	SOC	Description
LEDs show the SOC of batteries		$SOC \leq 5.2\%$
		$5.2\% < SOC \leq 9.5\%$
		$9.5\% < SOC \leq 25.2\%$
		$25.2\% < SOC \leq 50\%$
		$50\% < SOC \leq 75.2\%$
		$75.2\% \leq SOC \leq 100\%$

3.3.3. Battery Introduction

Battery pack appearance and Dimensions

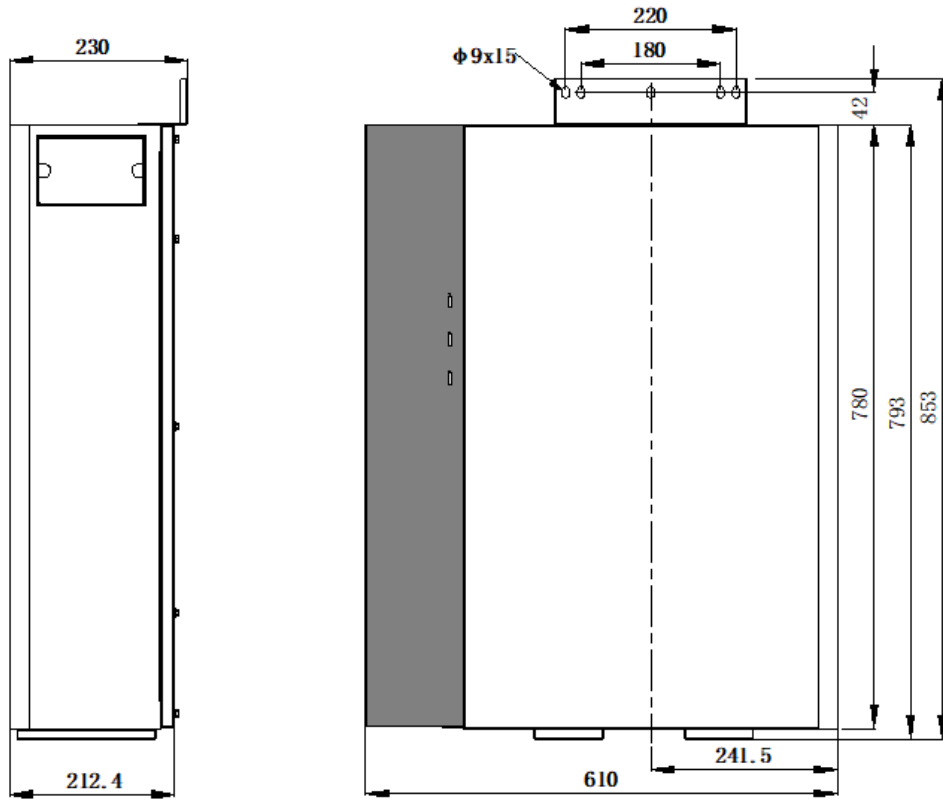

Connection area overview of SMILE-G3-BAT-10.1P

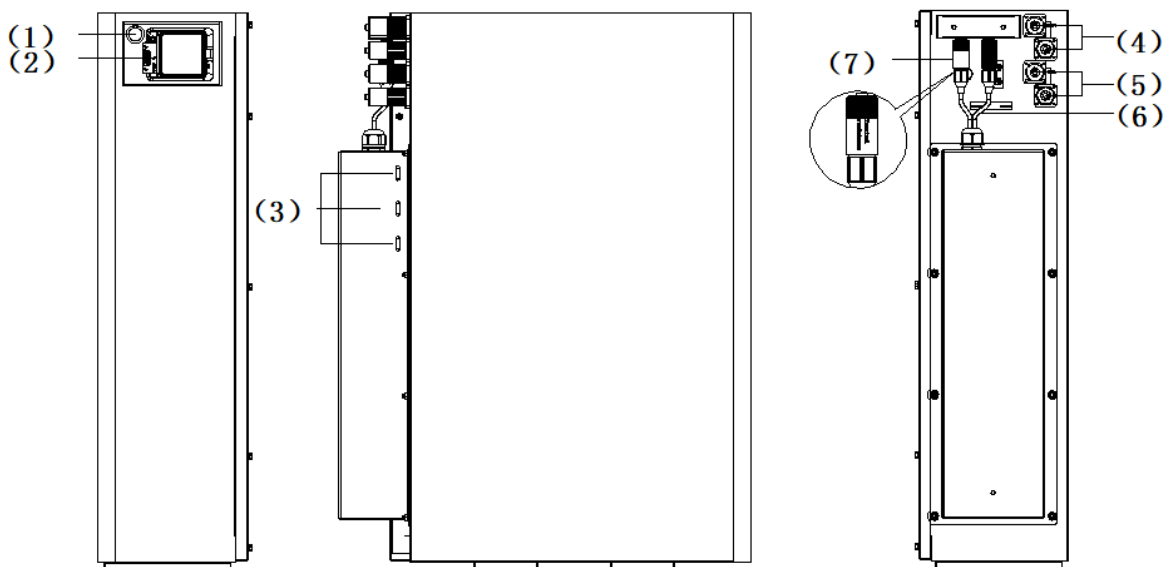

Position	Designation
1	Battery Power Button
2	Battery Breaker
3	Battery LED Display
4	Battery+ Power Connector
5	Battery- Power Connector
6	Grounding
7	BMS COM Ports

3.4. Application Scenarios

AlphaESS SMILE-G3 system (includes inverter SMILE-G3-INV and battery SMILE-G3-BAT-10.1P) can be applied in DC-coupled systems (mostly new installation), AC-coupled systems (mostly retrofit), Hybrid-coupled systems (mostly retrofit, and increase the PV capacity), and Off-grid (with Generator) systems as the following schemes show :

3.4.1. DC-coupled Storage System

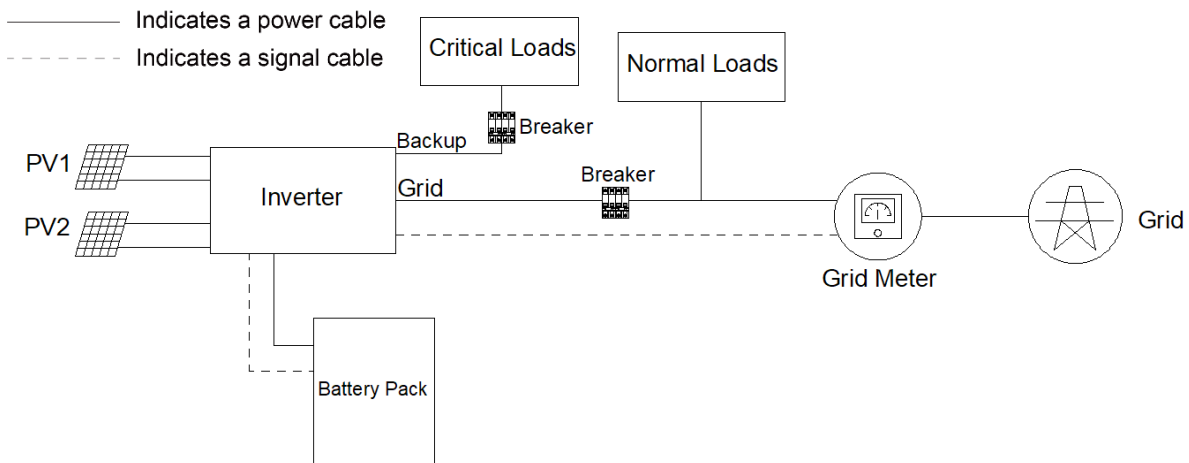

DC-coupled Storage System - Scheme

3.4.2. AC-coupled Storage System

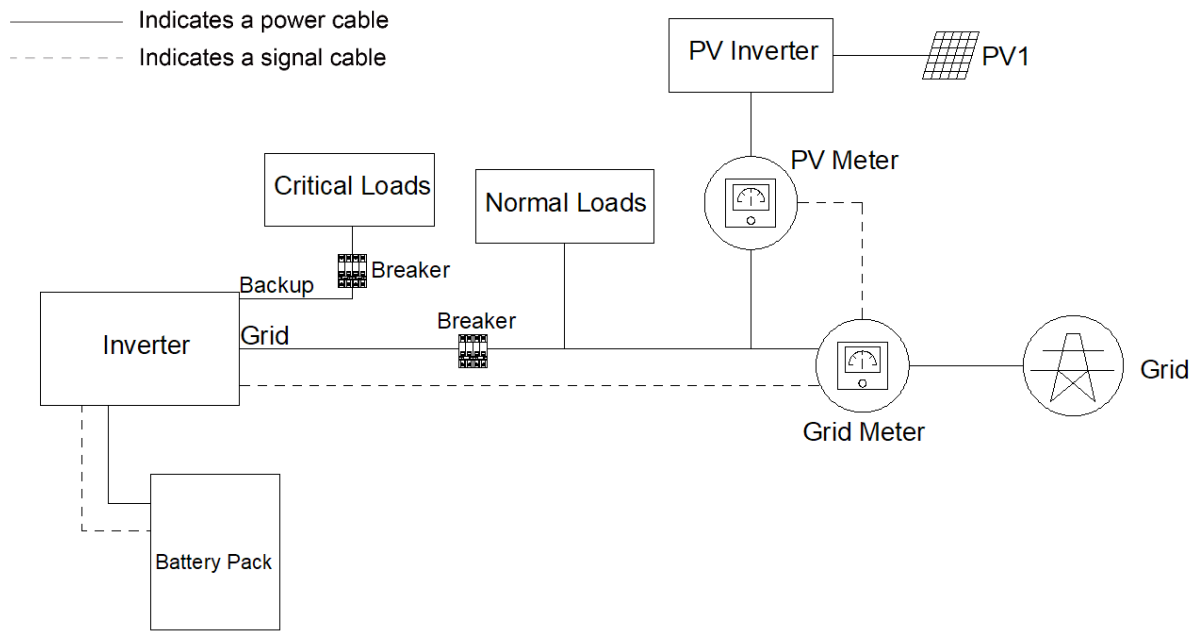

AC-coupled Storage System–Scheme

3.4.3. Hybrid-coupled Storage System

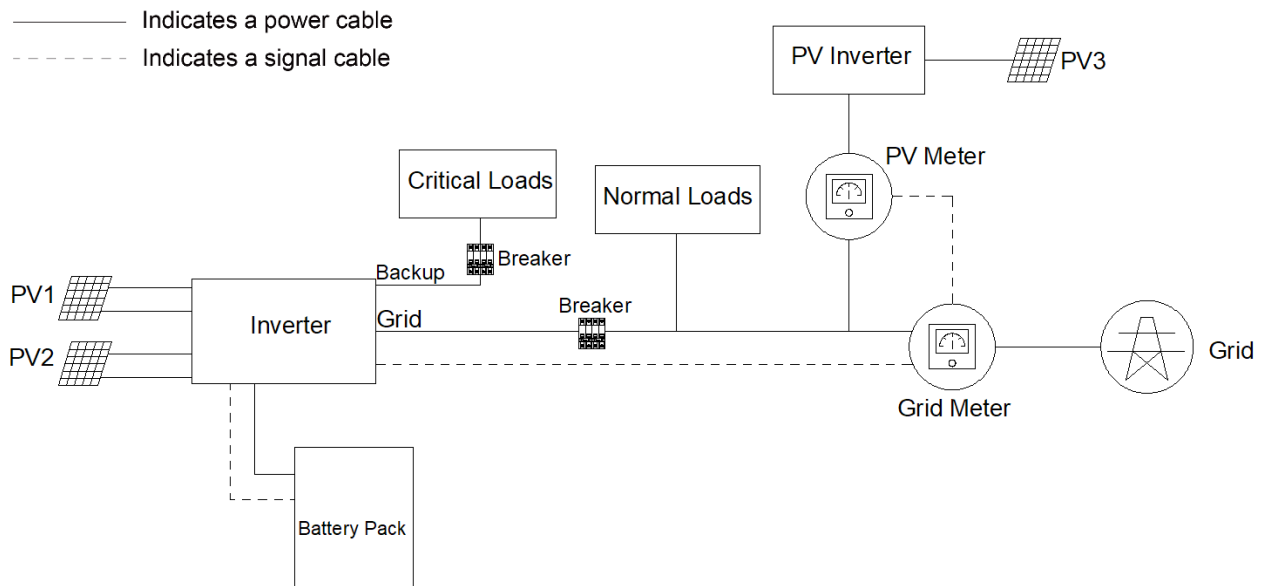

Hybrid-coupled Storage System - Scheme

4. Storage and Transport

4.1. Storage

4.1.1. Inverter Storage

The following requirements should be met if the inverter is not put into use directly:

1. Do not unpack the inverter.
2. Keep the storage temperature at $-40\sim 70^{\circ}\text{C}$ and the humidity at $5\%\sim 95\%$ RH.
3. The inverter should be stored in a clean and dry place and be protected from dust and water vapor corrosion.
4. A maximum of six inverters can be stacked. To avoid personal injury or device damage, stack inverters with caution to prevent them from falling over.
5. During the storage period, check the inverter periodically. Replace the packing materials which are damaged by insects or rodents in a timely manner.
6. If the inverters have been stored for more than two years, it must be checked and tested by professionals before being put into use.

4.1.2. Battery Storage

The following requirements should be met if the battery pack is not put into use directly:

1. Place batteries according to the signs on the packing case during storage. Do not put batteries upside down or sidelong.
2. Stack battery packing cases by complying with the stacking requirements on the external package.
3. Store the battery pack out of reach of children and animals.
4. Store the battery pack where it should be minimal dust and dirt in the area.
5. Handle batteries with caution to avoid damage.
6. The storage environment requirements are as follows:
 - a. Ambient temperature: $-10\sim 55^{\circ}\text{C}$, recommended storage temperature: $15\sim 30^{\circ}\text{C}$
 - b. Relative humidity: $15\%\sim 85\%$
 - c. Place batteries in a dry and clean place with proper ventilation.
 - d. Place batteries in a place that is away from corrosive organic solvents and gases.
 - e. Keep batteries away from direct sunlight.
 - f. Keep batteries at least 2 m away from heat sources.
7. The batteries in storage must be disconnected from external devices. The indicators (if any) on the batteries should be off.
8. Batteries should be delivered based on the "first in, first out" rule.

9. The warehouse keeper should collect battery storage information every month and periodically report the battery inventory information to the planning department. The batteries that have been stored for nearly 6 months should be recharged timely.
10. If a lithium battery is stored for a long time, capacity loss may occur. After a lithium battery is stored for 12 months in the recommended storage temperature, the irreversible capacity loss rate is 3%~10%. It is recommended that batteries not be stored for a long period. If the batteries need to be stored for more than 6 months, it is recommended to recharge the batteries to 65~75% of the SOC.

4.2. Transport

During transportation, please follow these guidelines:

1. Priority to use the original packaging for transportation. If the original packaging is not available, put the product inside a suitable cardboard box and seal it properly.
2. Handle with care, choose the corresponding handling method according to the weight, and pay attention to safety;

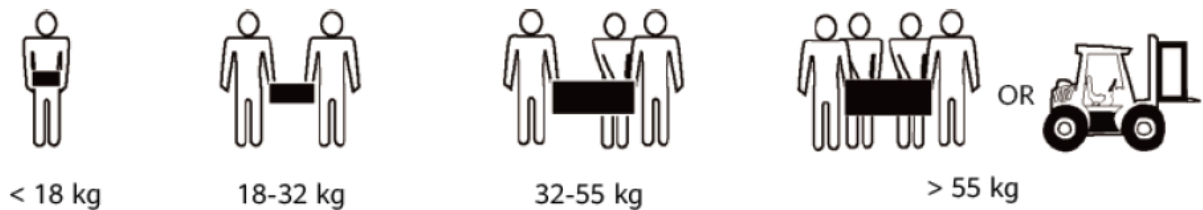

3. During transportation, please keep the packaging away from dangerous sources and take waterproof measures;
4. Please fix the packaging during transportation to prevent falling or mechanical impact;







5. Mounting

5.1. Checking the Outer Packing

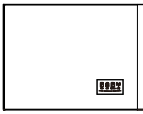

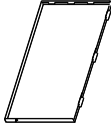
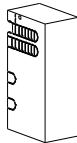
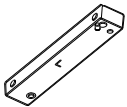
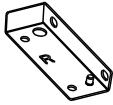
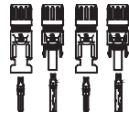
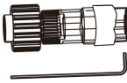

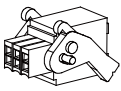

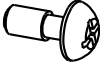
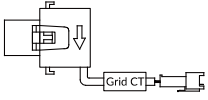
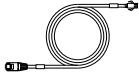
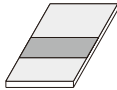

Before unpacking the product, check the outer packing for damage, such as holes and cracks. If any damage is found, do not unpack the product and contact your dealer as soon as possible.

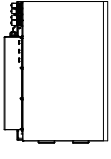
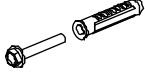
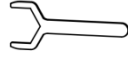
5.2. Scope of Delivery

Check the scope of delivery for completeness and any externally visible damage. Contact your distributor if the scope of delivery is incomplete or damaged.

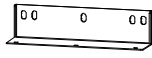
SMILE-G3-INV				
				
SMILE-G3-S5/S3.6/B5-INV (X1)	TOP decoration plate (X1)	Right decoration plate (X1)	Left decoration plate (X1)	Left Bracket (X1)
				
Right Bracket (X1)	PV+ & PV- Connectors (X2)*	AC Connector (X1)	BACK UP Connector (X1)	WiFi Module (X1)
				
6 Pin AUX Terminal Block (X1)	M5*12 Screw (X8)	Screw M4*10 (X2)	Grid CT (X1)	Grid CT Cable (X1)
				
Documentation sheets (X1)				

*Only for product SMILE-S3.6/S5;

SMILE-G3-BAT-10.1P			
			
Battery Pack (X1)	Wall Anchor ST6*55 (X4)	Spanner (X1)	Ring Terminal (x4)
			
Y type terminal (x2)	Left decoration plate (X1)	switch cover (x1)	Wall bracket (x1)
			
Screw M5*10 (X4)	Expansion Bat ± Power Cable (X1)	Battery Communication Cable (X1)	Quick Installation Guide (X1)

5.3. Requirements for Mounting



WARNING

Danger to life due to fire or explosion

Despite careful construction, electrical devices can cause fires.

- Do not mount the system in areas containing highly flammable materials or gases.
- Do not mount the system in potentially explosive atmospheres.

5.3.1. Basic Requirements

- The SMILE-G3 system is suitable for indoor and outdoor use.
- Do not install the inverter in a place where a person can easily touch it because its housing and heatsink are hot during operation.
- Do not mount the system in areas with flammable or explosive materials.
- Do not mount the inverter at a place within children's reach.
- Do not mount the system outdoors in salt areas because it will be corroded there and may cause fire. A salt area refers to the region within 500m from the coast or prone to sea breeze. The regions prone to sea breeze vary depending on weather conditions (such as typhoons and monsoons) or terrains (such as dams and hills).

5.3.2. Mounting Environment Requirements

- The system must be mounted in a well-ventilated environment to ensure good heat dissipation.
- When mounted under direct sunlight, the power of the system may be derated due to additional temperature rise.
- Mount the system in a sheltered place or mount an awning over the product.
- The optimal temperature range for the battery pack to operate is from 15 to 30°C.
- Do not expose or place near water sources like downspouts or sprinklers.
- If the battery pack is mounted in the garage, then ensure that it is above the height of the vehicle bumper and/ or door.

5.3.3. Mounting Structure Requirements

- The mounting structure where the system is mounted must be fireproof.
- Do not mount the system on flammable building materials.
- Ensure that the mounting surface is solid enough to bear the weight load.
- In residential areas, do not mount the inverter on drywalls or walls made of similar materials which have a weak sound insulation performance because the noise generated by the inverter is noticeable.

5.3.4. Mounting Angle and Stack Requirement

The inverter should be mounted on the wall.

The installation angle requirement is as follow:

- Do not mount the inverter at forward tilted, side tilted, horizontal, or upside down positions.

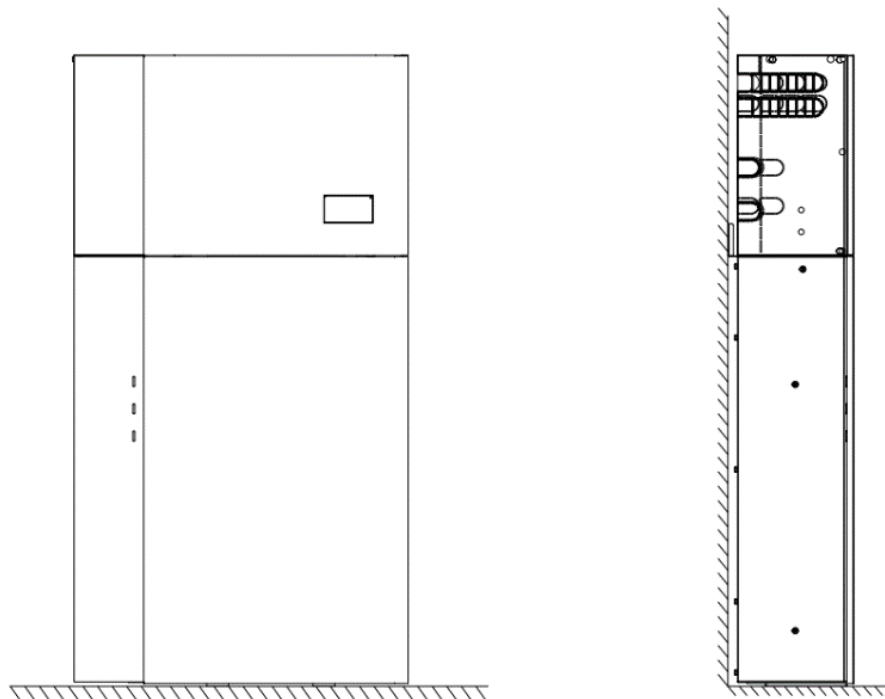







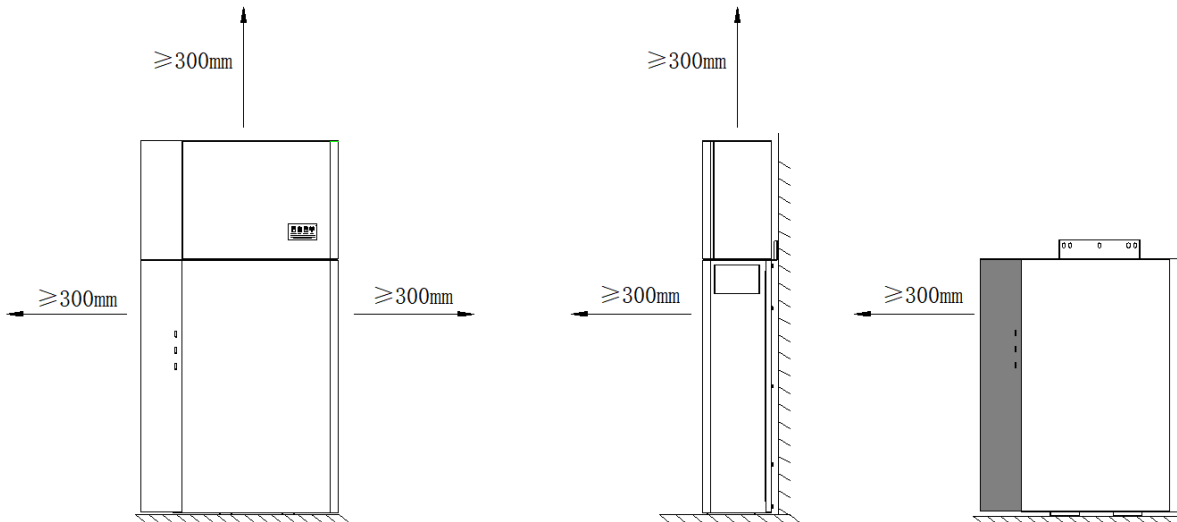







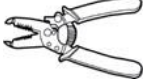







5.3.5. Mounting Space Requirements

- Reserve sufficient clearance around the product to ensure sufficient space for installation, maintenance and heat dissipation.
- The side clearance is a recommendation. Keep the clearance as short as you can if there is no influence to the operation and maintenance.

Recommended clearances



5.4. Preparing Tools and Instruments

Category	Tools and Instruments		
Installation			
	Hammer drill (with a $\Phi 10$ mm drill bit)	Torque socket wrench SW10	Multimeter (DC voltage range ≥ 1000 V DC)
			
	Diagonal pliers	Wire stripper	T20 screwdriver (torque range: 0-5 N m) L < 200mm
			
	Rubber mallet	Utility knife	Cable cutter
			
	Crimping tool (model: PV-CZM-22100)	Cord end terminal crimper	Disassembly and Assembly Tool of PV connector
			
	Vacuum cleaner	Heat shrink tubing	Heat gun
			
Marker	Measuring tape	Bubble or digital level	
Personal Protective Equipment			
	Safety gloves	Safety goggles	Anti-dust respirator
			
Safety shoes			

5.5. Mounting the Product

5.5.1. Mounting the Battery

- a. Take out the battery from the carton, transport it to the installation site with a handcart which bearing capacity should be greater than 200kg, tied with bandage.
- b. Place the battery against the wall, mount the wall panels and then mark drill positions.
- c. Fix the bolt wall bracket on the box with 3pcs M5*10 screws;

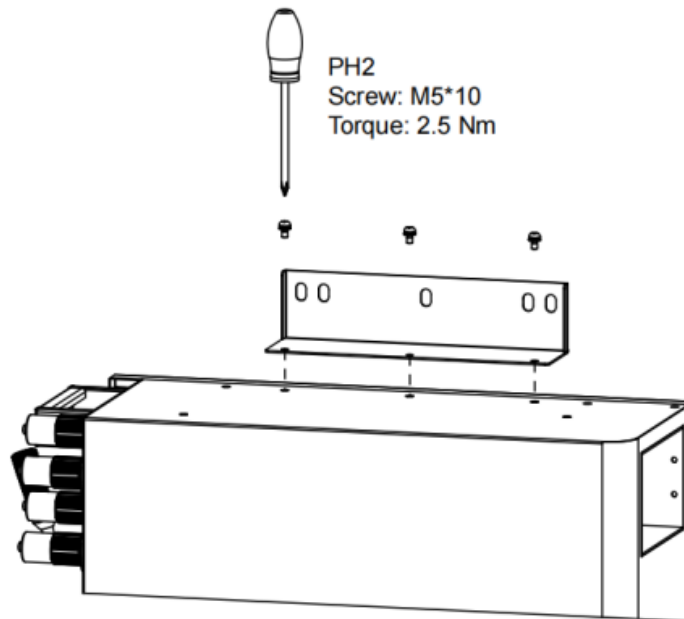

- d. Select a set of symmetrical OB holes for tracing points, and remove the product after tracing points are completed;

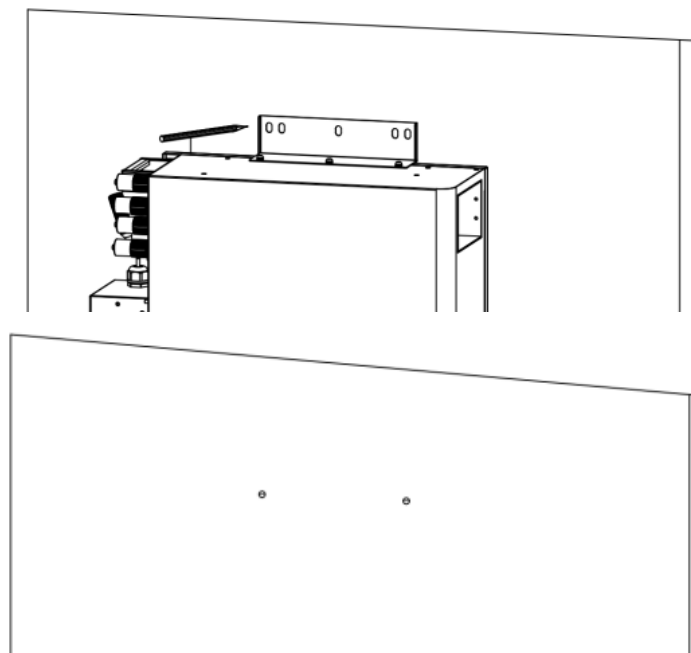

- e. Drill 2 holes on the wall with a diameter of 10mm and a depth of about 70mm.

f. After cleaning the dust and other objects from the two holes, place 2 wall anchors into the holes, then attach the battery wall bracket to the wall by using the SW10 hexagon sleeve. Please use a level to ensure that the wall bracket is horizontal.

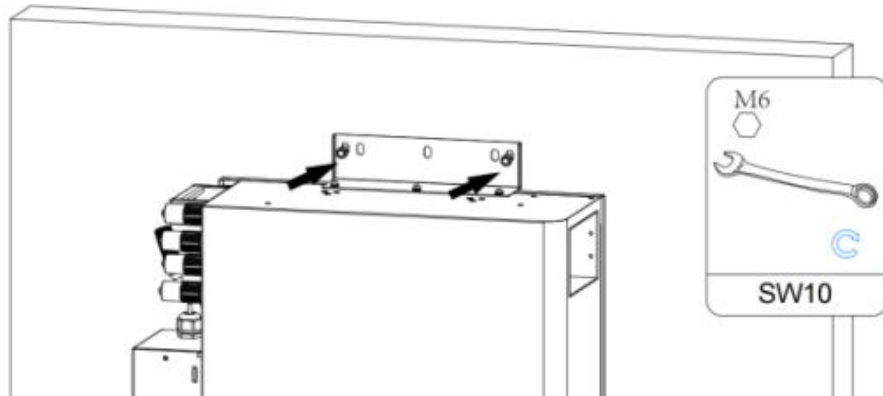

For mounting multiple batteries, please follow as above steps.

If you will install extra batteries by side, please keep the distance between two batteries greater than 300mm. You can install extra batteries up to 6 batteries in a system.

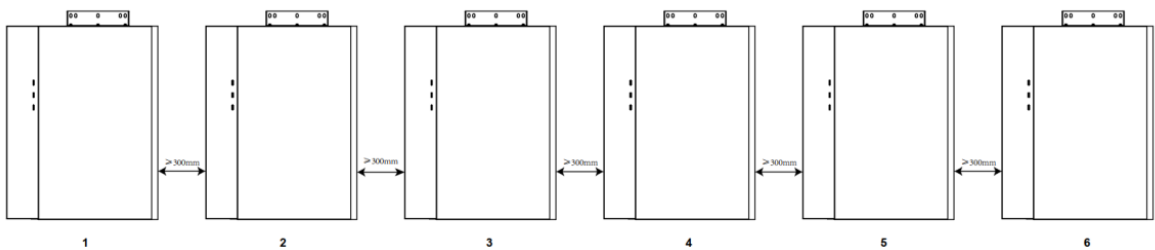

5.5.2. Mounting the Inverter

a. Fit the left and right side brackets onto the top of the battery

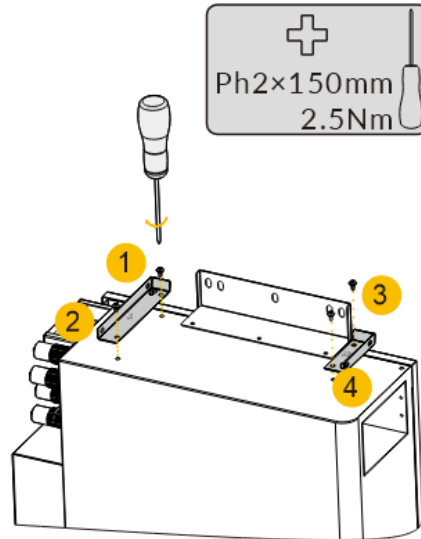

b. Attach the inverter to the mounting bracket. Mount the supporting bracket at the bottom of the inverter.

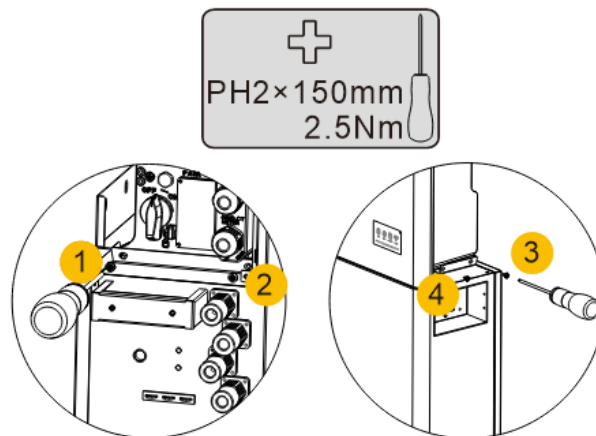
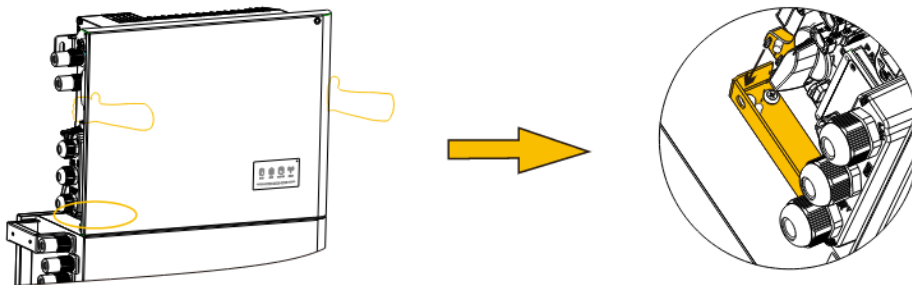

5.5.3. Mounting the WiFi Module

a. Remove the WiFi Silicone dust cover from the left of the inverter.

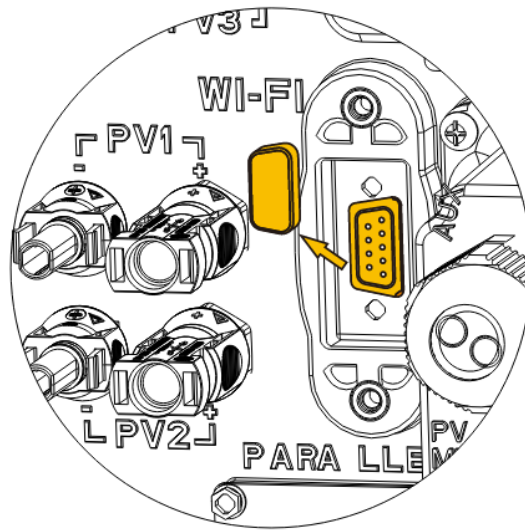

b. Tighten the Wi-Fi module onto the inverter with screw M4*10 (X2)
(Tool: PH2 screwdriver, torque: 2.0 Nm).

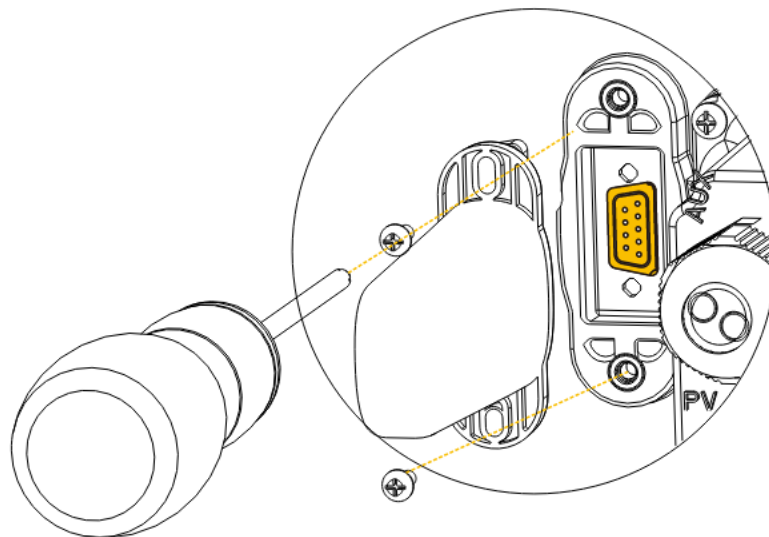

6. Electrical Connection

Precautions

 **DANGER**

Before connecting cables, ensure that all breakers of the inverter and the battery packs and all the switches connected to inverters and the battery packs are set to OFF. Otherwise, the danger voltage of the energy storage system may result in electric shocks.

 **WARNING**

- The energy storage system damage caused by incorrect cable connections is not covered under any warranty.
- Only certified electricians are allowed to connect cables.

Operation personnel must wear proper PPE when connecting cables

 **NOTICE**

The cable colors shown in the electrical connection diagrams provided in this chapter are for reference only.

Select cables in accordance with local cable specifications (green-and-yellow cables are only used for PE).

6.1. Cable Requirements for Connection

No.	Cable	Type	Conductor Cross Section Area Range	Outer Diameter	Source
1	Battery power cable	Standard PV cable in the industry (recommended type: PV1-F)	16mm ²	N/A	Delivered with the battery
2	Battery communication cable	Standard network cable in the industry (recommended type: Cat5e, UTP, UV-resistant for outdoor use)	0.12 ~ 0.2 mm ² (AWG26~AWG24)	N/A	Delivered with the battery
3※1	Signal cable	Standard network cable in the industry (recommended type: Cat5e, FTP, UV-resistant for outdoor use)	0.12 ~ 0.2 mm ² (AWG26~AWG24)	N/A	Delivered with the battery
4	PV Power cable	Standard PV cable in the industry (recommended type: PV1-F)	4~6 mm ²	5.5 ~ 9 mm	Purchased by the installer
5※2	Signal cable	Standard network cable in the industry (recommended type: Cat5e, FTP, UV-resistant for outdoor use)	0.12 ~ 0.2 mm ² (AWG26~AWG24)	4~6 mm	Purchased by the installer
6※3	Signal cable	Multiple-core outdoor shielded twisted pair cable	0.1 ~ 1.3 mm ²	4~6 mm	Purchased by the installer
7	AC power cable for backup	Three-core (L, N and PE) outdoor copper cable	4 ~ 6 mm ²	10 ~ 14 mm	Purchased by the installer
8	AC power cable for grid	Three-core (L, N and PE) outdoor copper cable	6 ~ 8mm ²	13 ~ 18 mm	Purchased by the installer
9	PE cable	Single-core outdoor copper cable	6 ~ 10 mm ²	N/A	Purchased by the installer

※1 For CT communication connection with inverter.

※2 For CAN/RS485, LAN, Meter, DRM communication connection with inverter.

※3 For AUX communication connection with inverter.

6.2. Connecting Additional Grounding

! NOTE

Electric Shock Hazard

Before doing electrical connection, please ensure the PV switch & all AC and BAT circuit breakers in the energy storage system are switched OFF and cannot be reactivated.

An external grounding bar is provided at the bottom of the SMILE-G3-INV.
 Prepare M5 OT terminals, strip the grounding cable insulation, insert the stripped part of the grounding cable into the ring terminal lug and crimp using a crimping tool.
 Connect the OT terminal to ground bar using the torque is 2.5 Nm with T20 screwdriver.
 Additional grounding connection for SMILE-G3-INV.

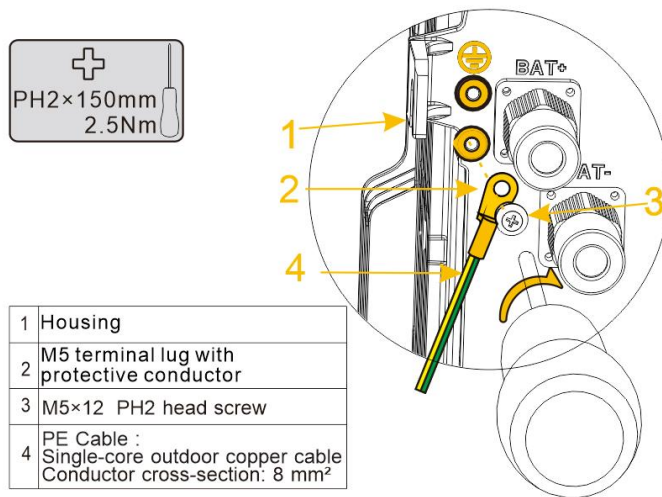

Grounding connection between inverter SMILE-G3-INV and battery Smile-Bat series.

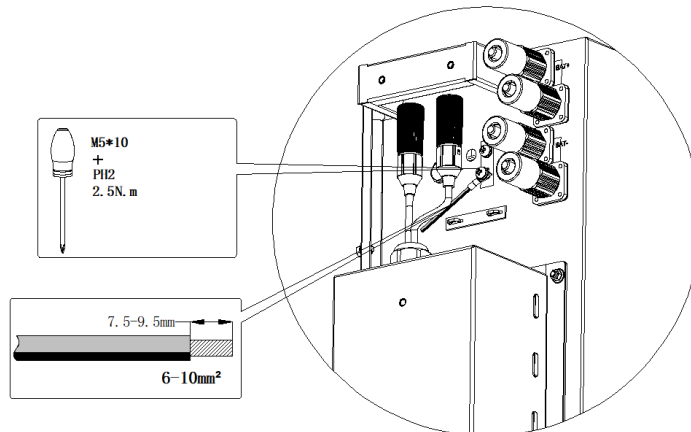

6.3. AC Connection

6.3.1. Requirements for the AC Connection

AC cable requirements as follows:

- Conductor type: copper wire
- External diameter: 12 mm to 18 mm for grid connector, 10 mm to 14 mm for backup connector,
- Conductor cross-section recommendation: 6-8 mm²
- Insulation stripping length: 10 mm
- Sheath stripping length: 50 mm

 **NOTE**

Residual-current monitoring unit:

The inverter does not require an external residual-current device when operating.

If local regulations require the use of a residual-current device, or Hybrid-coupled storage system with big coupling capacity from the PV array and PV inverter, the following must be observed:

The inverter is compatible with type A residual-current devices with a rated residual current of 100 mA or higher. Each inverter in the system must be connected to the utility grid via a separate residual-current device.

 **DANGER**

You must protect each inverter with an individual grid/backup circuit breaker in order to ensure that the inverter can be disconnected safely.

 **NOTE**

For Australia and New Zealand installation site, the neutral cable of grid side and backup side must be connected together, otherwise backup output function will not work.

Description	Max. Current	Breaker Type for Smile-G3-S5/B5-INV
Grid Side	43.5A	63A
Backup Side	21.7A	32A

Description	Max. Current	Breaker Type for Smile-G3-S5/B5-INV
Grid Side	31.2A	63A
Backup Side	15.6A	32A

6.3.2. Grid and Backup Connection

The steps for connecting the grid connector as follows:

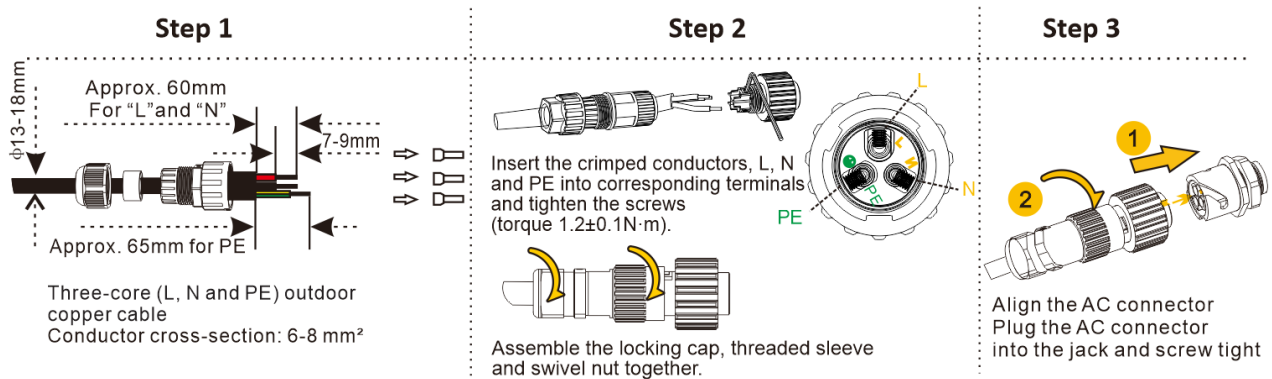

⚠ Note: Please ensure that the connector has been correctly installed!

The steps for connecting the backup connector as follows:

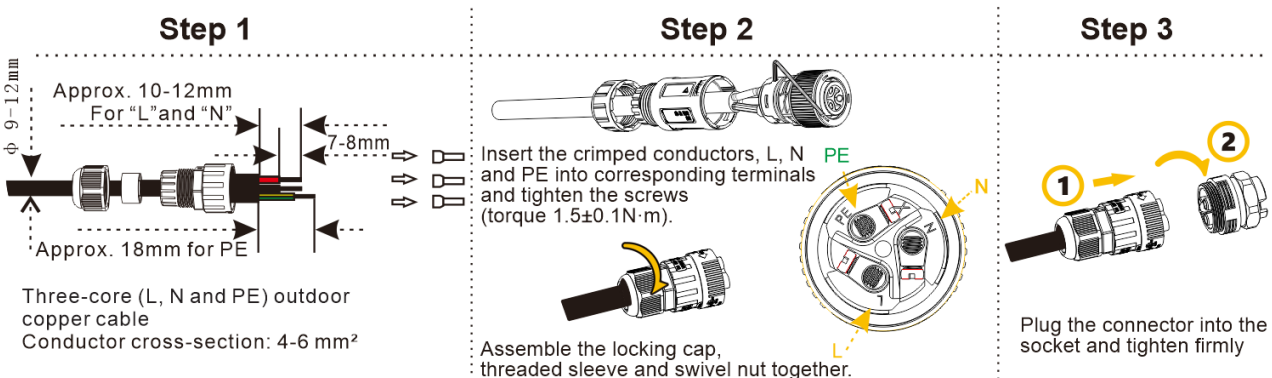

⚠ Note: Please ensure that the connector has been correctly installed!

6.3.3. CT Connection & Electricity Meter Connection

Item	Current	Scenarios
CT	100A	CT
DTSU666-3*230V 5(80)A	80A	Three phase meter (without CT)
DTSU666-3*230V 100A/40mA	100A	Three phase meter (with CT)
DTSU666-3*230V 250A/50mA	250A	Three phase meter (with CT)

Loosen the swivel nuts of the cable glands on the COM connection cover of SMILE-G3-INV, and unscrew the 4 screws on the corners, then you will see the grid CT, PV CT and meter communication ports.

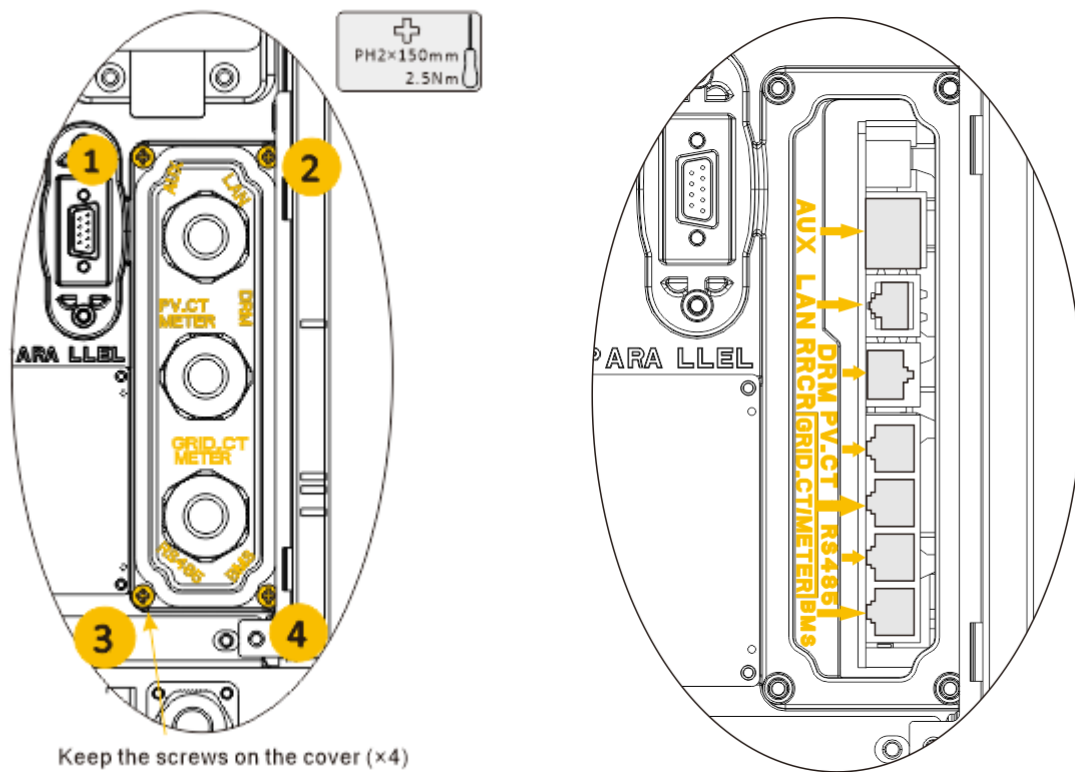

6.3.4. CT Connection

There are Grid CT & cable as accessory for SMILE-G3-INV.

For hybrid or AC-coupled storage system application, installer need to purchase PV CT & PV CT cable.

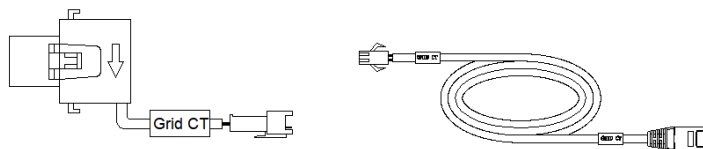

Please take out CT(s) from the package.

Step 1: Lead the CT cable through the cable gland of the COM connection cover, don't tighten the swivel nuts of the cable glands.

Insert the RJ45 plugs to the relative RJ45 sockets.

Step 2: Buckle the magnetic buckle of the Grid CT on the house-service live cable.

The arrow on the magnetic buckle of the Grid CT should point to the Grid port of Smile-G3-inverter.

Step 3: For hybrid or AC-coupled storage system application, buckle the magnetic buckle of the PV CT on the live cable of the installed PV inverter. The arrow on the magnetic buckle of the PV CT should point to the mains grid.

Step 3: Connect the CT cables to the Grid CT and PV CT respectively.

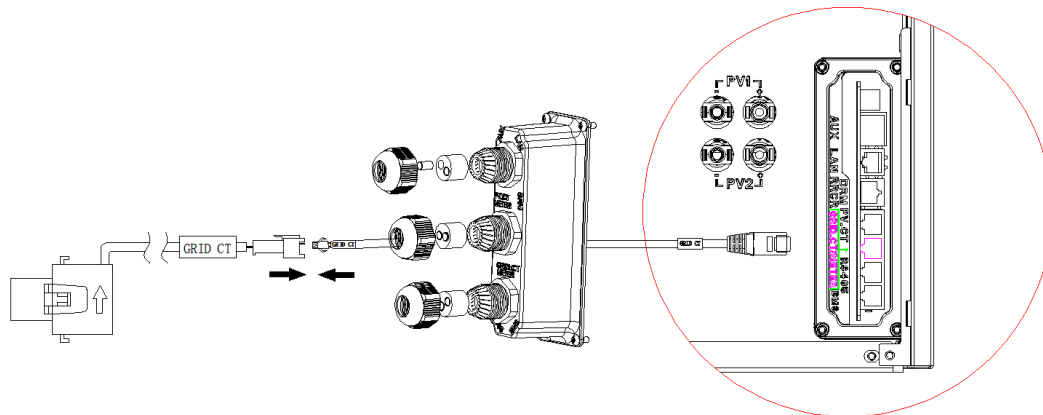

⚠ NOTE

The CT cable marked Grid CT should be connected to the Grid CT, and the CT cable marked PV CT should be connected to the PV CT.

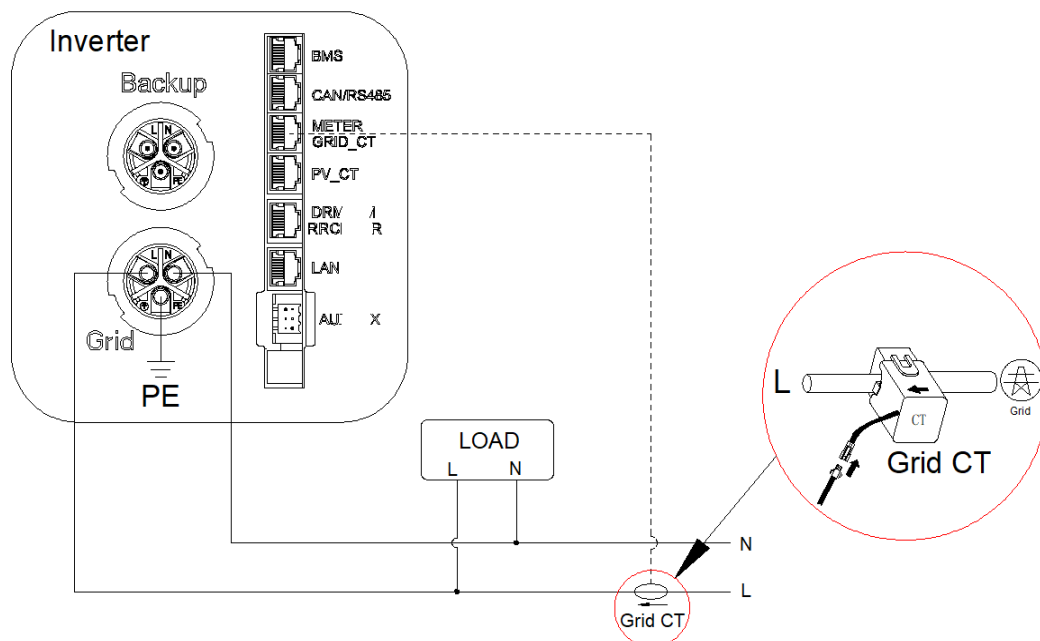

DC-coupled Storage System

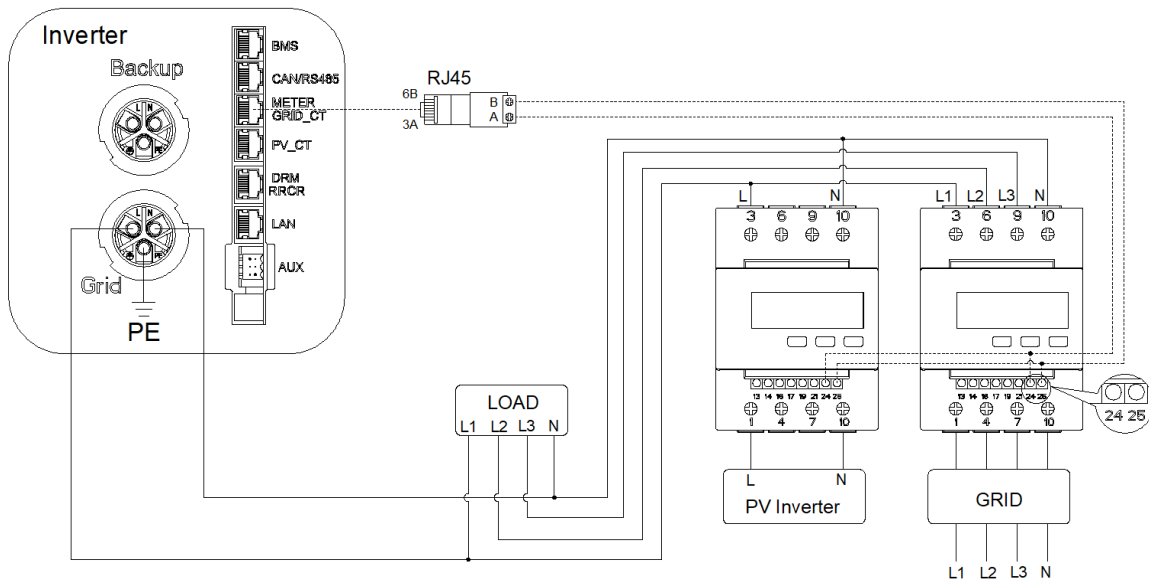

Wiring at three-phase feed in

2. DSTU666-3*230V 100A/40mA, DTSU666-3*230V 250A/50mA: Three phase meter (with CT) connection

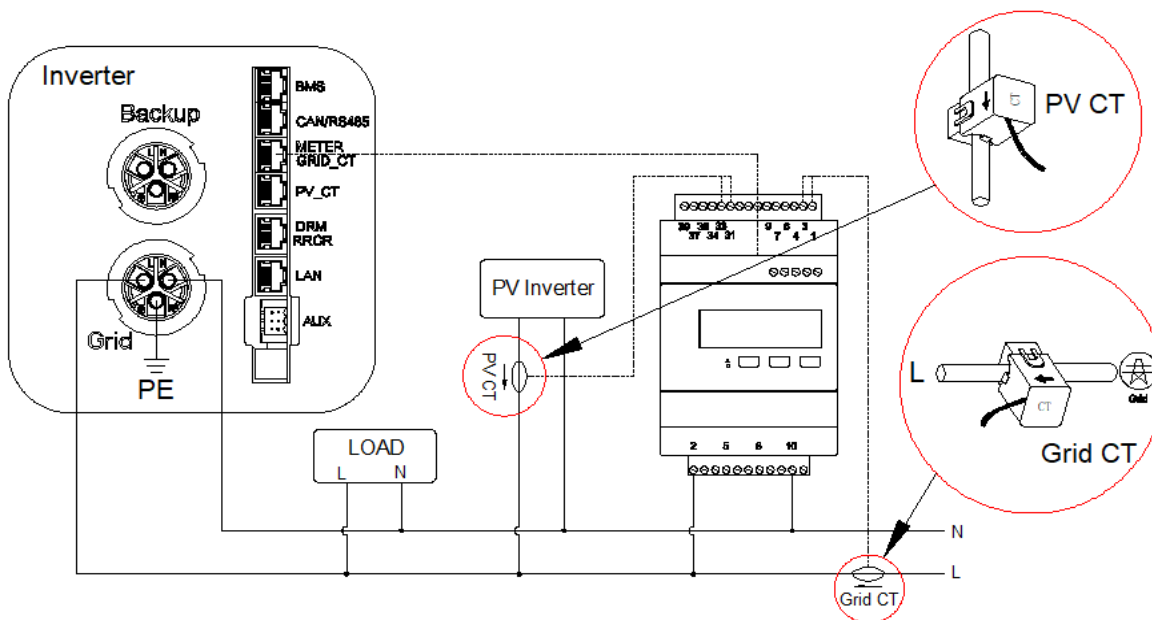

Wiring at single-phase feed in

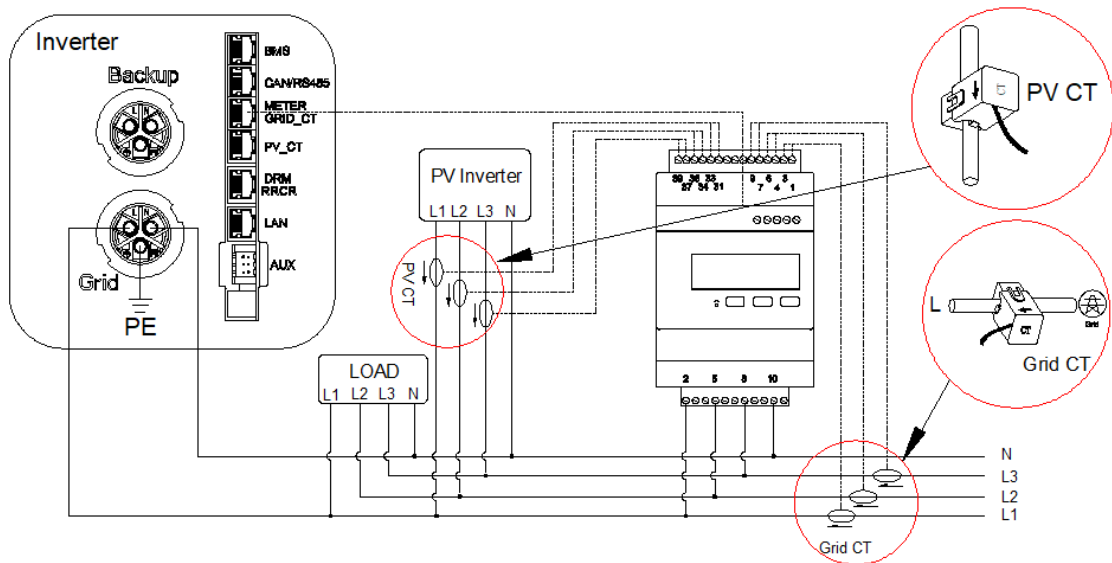

Wiring at three-phase feed in

Grid CT	PV CT	GRID
1-----IC (White)	31-----IC (White)	2-----L1
3-----IC (Blue)	33-----IC (Blue)	5-----L2
4-----IB (White)	34-----IB (White)	8-----L3
6-----IB (Blue)	36-----IB (Blue)	10----- N
7-----IA (White)	37-----IA (White)	
9-----IA (Blue)	39-----IA (Blue)	

6.3.6. Configuring the Chint Meter

Model	Grid Meter Address	PV Meter Address
DTSU666-3*230V 5(80)A (without CT)	1	2
DTSU666-3*230V 100A/40mA (with CT)	1	N/A
DTSU666-3*230V 250A/50mA (with CT)	1	N/A

1.DTSU666-3*230V 5(80)A: Three-phase meter (without CT)

When the meter is used as Grid meter, please follow the steps below to complete the address setting.

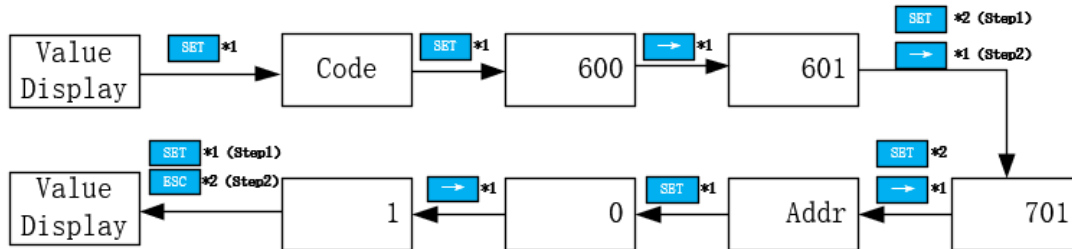

When the meter is used as PV meter, please follow the steps below to complete the address setting.

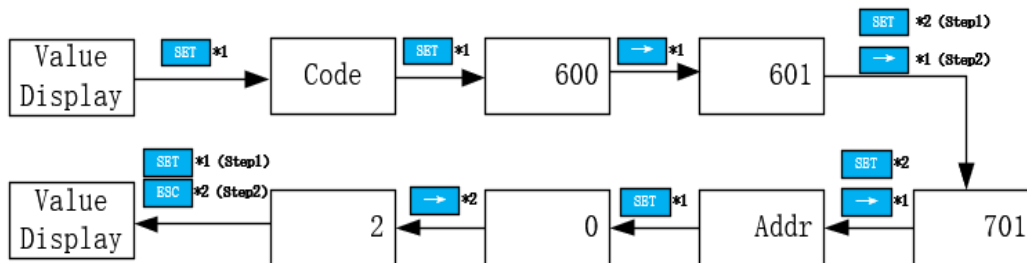

2.DTSU666-3*230V 100A/40mA,DTSU666-3*230V 250A/50mA: Three-phase meter (with CT)

When the meter is used as Grid meter, please follow the steps below to complete the address setting.

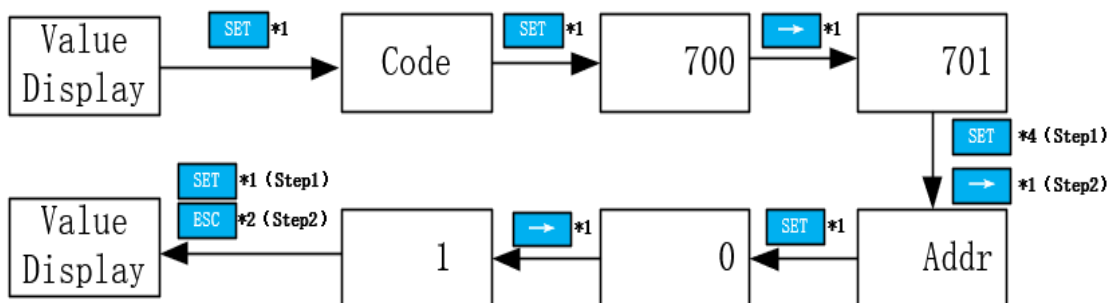

Meter Setting on AlphaCloud

Step 1:

When the system work mode is selected as DC, click the button under the "Grid Meter" to turn the "Meter" icon green.

When the system work mode is selected as AC or Hybrid, click the buttons under the "Grid Meter" and "PV side meter" to turn the "Meter" icon green.

Step 2:

Click "Save" and wait a few minutes to refresh the page.

When the "Meter Model" displays DTSU666 model, the setting is successful.



NOTE

It is forbidden to tick CT to modify the CT ratio.

Meter Information

Grid Meter

Meter CT **CT** ⓘ

CT ⓘ Meter CT Ratio ⓘ Meter Model

PV side meter

Meter CT **CT** ⓘ

CT ⓘ Meter CT Ratio ⓘ Meter Model

Meter Setting on AlphaAPP

Step 1:

When the system work mode is selected as DC, only tick "Meter" icon on the right of the "Grid Meter".

When the system work mode is selected as AC or Hybrid, both tick "Meter" icon on the right of the "Grid Meter" and "PV side meter".

Step 2:

Click "Submit" and enter the "System information" page to check the meter model. When the "Meter Model" displays DTSU666 model, the setting is successful.



NOTE

It is forbidden to tick CT to modify the CT ratio.

5:30 System Configuration

← Connect to the hotspot Router Configuration System Configuration

Work Mode ⓘ DC >

On Grid PV Capacity ⓘ 3 kW

Storage PV Capacity ⓘ 5 kW

Grid Meter CT Meter

PV Meter CT Meter

Safety Regulations AS4777.2:2020 >

Regional application standard ⓘ Australia A

Max.Feed-in(%) 100

Submit

6.4. PV Connection

Please ensure the follows before connecting PV strings to the SMILE-G3-INV:
 Make sure the open voltage of the PV strings will not exceed the max. DC input voltage (580Vdc). Violating this condition will void the warranty.
 Make sure the polarity of the PV connectors is correct.
 Make sure the PV-switch, breakers of battery, AC-BACKUP and AC-Grid are all in their off-states.

- Make sure the PV resistance to ground is higher than 200KOhms.

The inverter uses the Vaconn D4/MC4(optional) PV connectors. Please follow the picture below to assemble the PV connectors.

PV conductor cross section requirements: 4~6 mm²

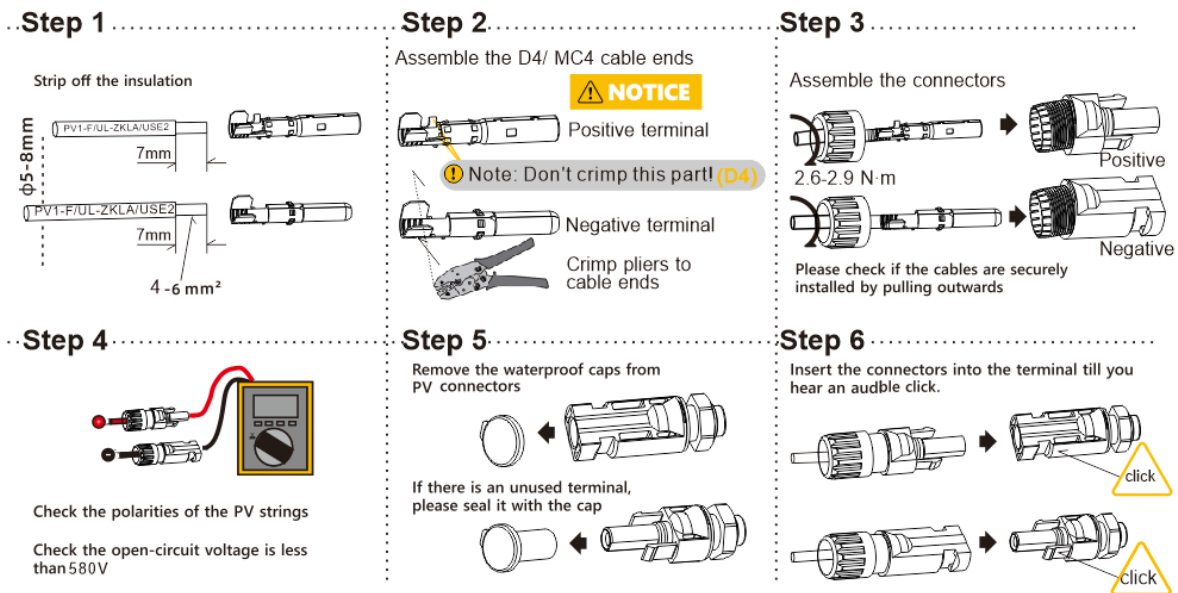

6.5. Electrical Connection Between the Inverter and Battery Packs

6.5.1. Electrical Connection Between the Inverter and SMILE-Bat series

Communication cable connection:

- Take out the battery communication cable from the battery package
- Lead the battery communication cable through the cable gland of the COM connection cover of SMILE-G3-INV, don't tighten the swivel nuts of the cable glands, insert the RJ45 plugs to the BMS communication port.
- The battery communication ports of Smile-Bat series are at the top right of the battery, unscrew the 4 screws of the communication panel and remove it.
- Loosen the swivel nut of the cable gland on the battery communication panel, lead the battery communication cable through the cable gland, insert the RJ45 plugs to the BMS communication port of Smile-Bat series.
- Tighten the 4 screws of the communication panel, then tighten swivel nut of the cable gland.

Power cable connection:

- Take out the battery power cables from the battery package.
- Remove the protective caps from the battery power connectors.
- Connect the battery power cables to the SMILE-G3-INV and battery packs.
Please pay attention to the cable polarity, red cable is for battery positive.

For electrical connection between multiple battery packs, please follow as above steps.

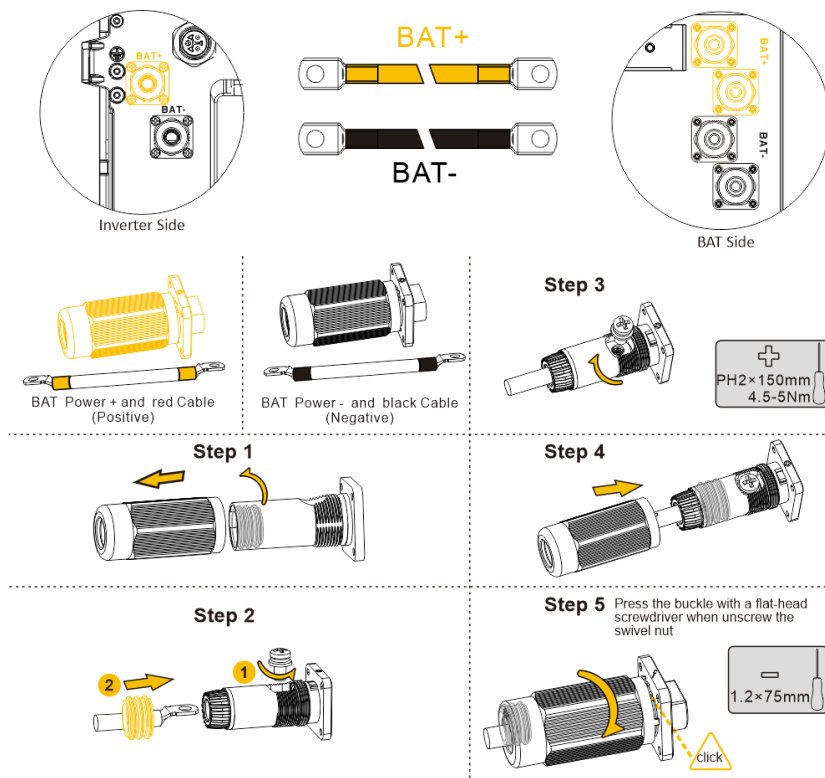

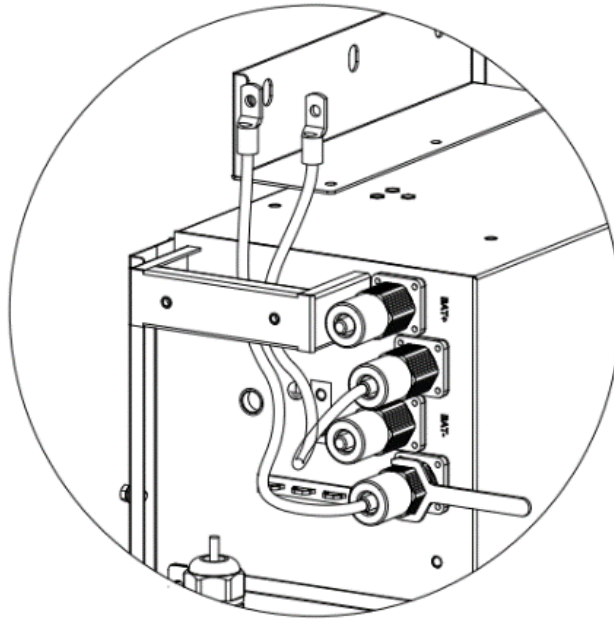
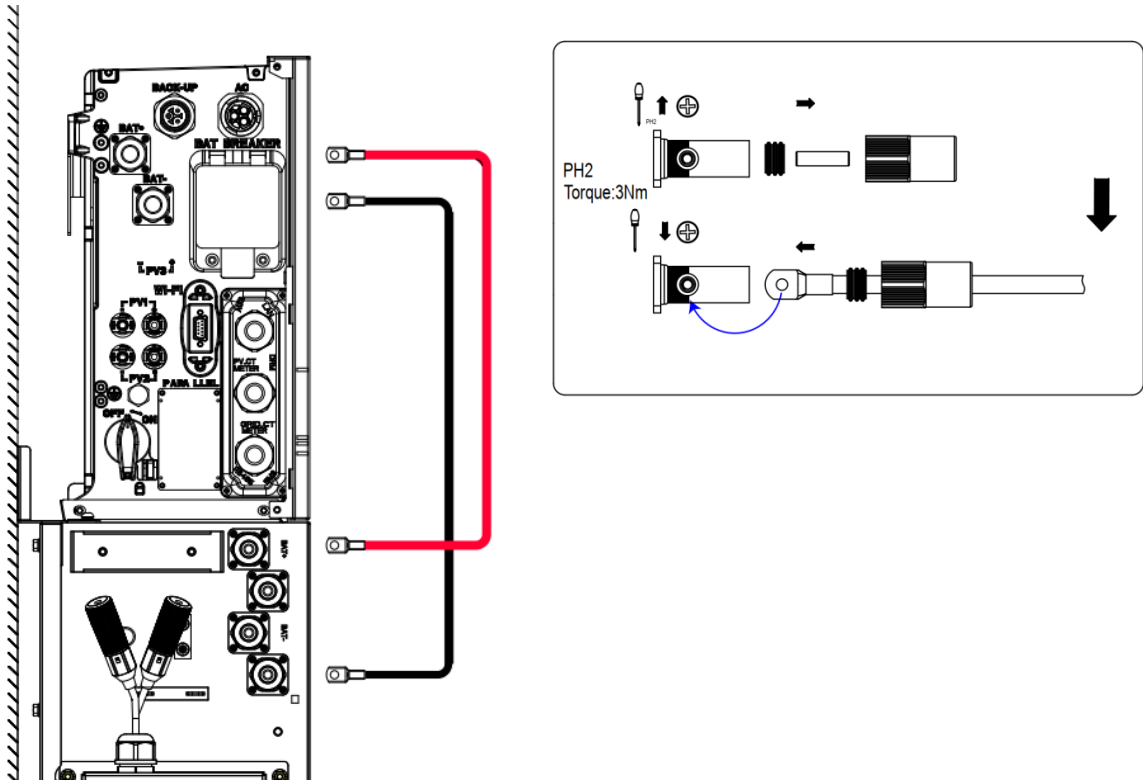

6.5.2. AUX/LAN/PV-CT/DRM、RRCR/GRID-CT、Meter/RS485/BMS Connection

For other communication (AUX, LAN, RRCR, DRM, Meter, RS485) connection, please follow the below steps.

1. Loosen the cable glands on the COM connection cover, and then unscrew the 4 screws on the COM connection cover.

2. Lead the communication cables through the cable glands of the COM connection cover, don't tighten the swivel nuts of the cable glands.

Insert the RJ45 plugs to the relative RJ45 sockets.

- 1) For meter wiring, refer to Chapter 6.4.2 and 6.4.3 for Chint or Acrel Meter Connection.
- 2) If DRM support is specified, the system may only be used in conjunction with a Demand Response Enabling Device (DRED). This ensures that the system implements the commands from the grid operator for active power limitation at all times. The system and the Demand Response Enabling Device (DRED) must be connected in the same network. Only DRM0 is available for SMILE-G3-INV.
- 3) Take out 6 pin terminal block for AUX connection. To do wiring connection, insert a screwdriver (blade width: 1.2 mm) into the relative connection position side. For AUX position definition, please see the AUX wiring documentation.

3. Place the COM connection cover against the inverter housing and tighten the 4 screws, at last secure the swivel nut of the cable glands.

The pin definition of the communication ports:

AUX	1	2	3	4	5	6		
	DO1_NO	DO1_COM	DO1_NC	DO2_NO	DO2_COM	DO2_NC		
DRM RRCR	1 DRED 1/5	2 DRED 2/6	3 DRED 3/7	4 DRED 4/8	5 REF GEN/0	6 COM LOAD/0	7 /	8 /
PV_CT	1 /	2 /	3 RS485_A7	4 /	5 /	6 RS485_B7	7 /	8 /
GRID_CT METER	1 /	2 /	3 RS485_A7	4 /	5 /	6 RS485_B7	7 /	8 /
RS485	1 /	2 /	3 /	4 RS485_B5	5 RS485_A5	6 /	7 /	8 /
BMS	1 /	2 RS485_A4	3 /	4 CAN1_H	5 CAN1_L	6 /	7 RS485_B4	8 /

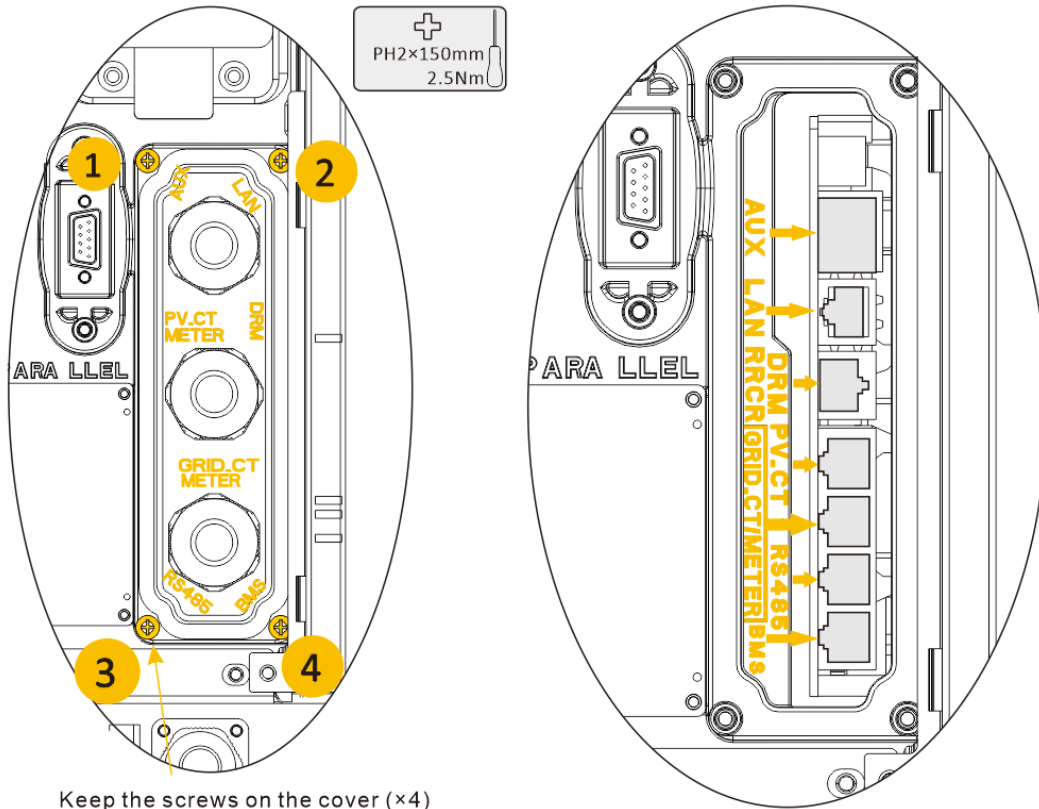

Keep the screws on the cover (x4)

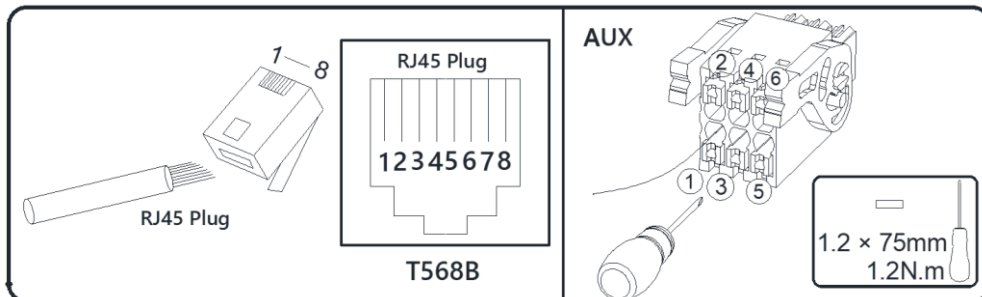

6.6. Mounting the Battery and Inverter decoration plates

After finishing electrical connection of energy storage system, do the following operations.

1. Install the plastic decorative cover of the Battery

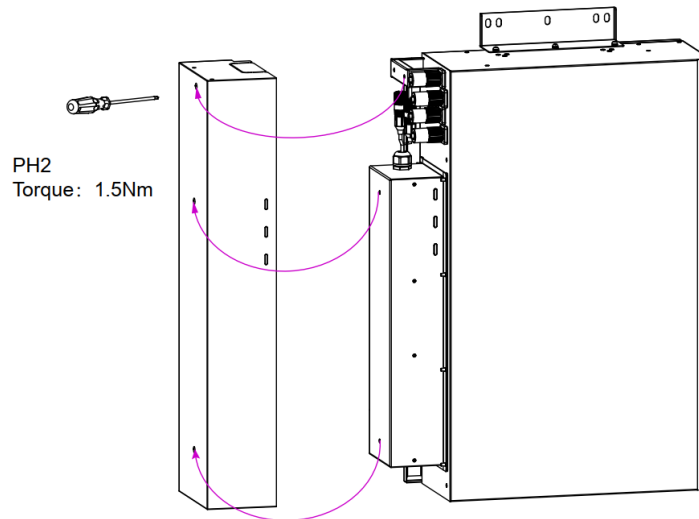

2. Install the top and right decorative cover of the inverter

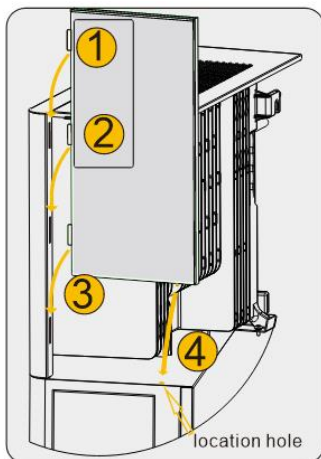
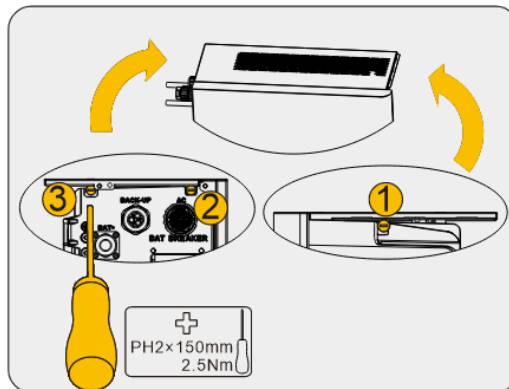
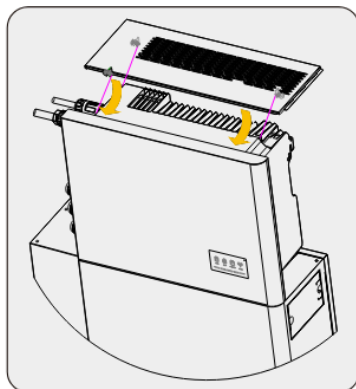

7. Installer Account Register and Install New System

7.1. Register on APP

7.1.1. Download and Install APP

1. Android device users can download the App through major Android application markets such as Google Play.
2. IOS device users can search for "AlphaCloud" in App Store and download the App.



AlphaCloud

7.1.2. Register as Installer Account

If you don't have an installer account, please register firstly.

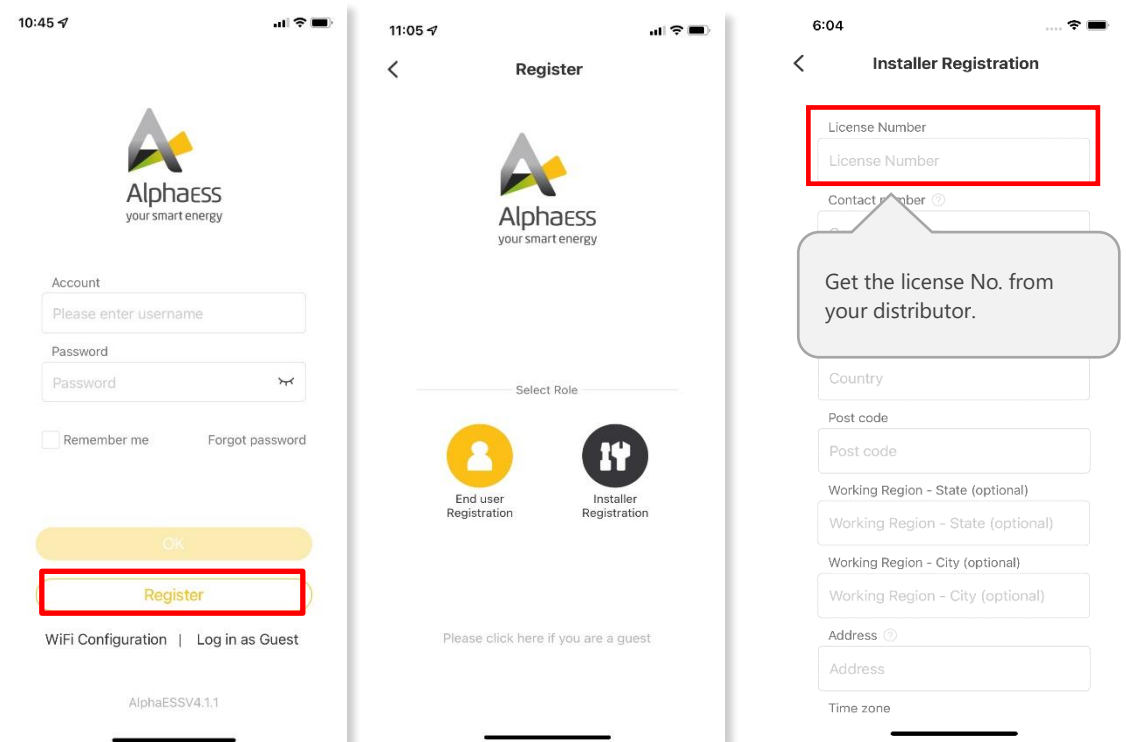

If you already have an installer account, please log in directly.

7.1.3. Overview of Functions for Installer Account



7.1.4. Install New System

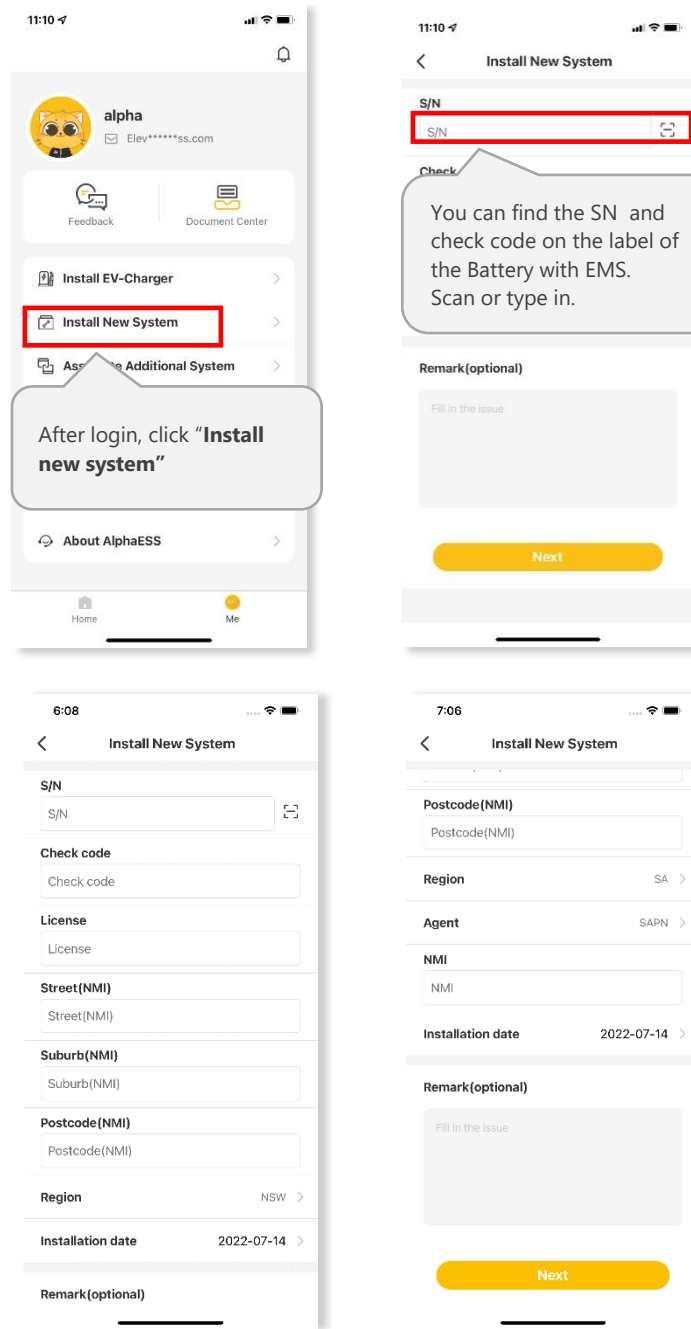

Australian Installer

Please enter your installer account and click install New system to bind the system to your account and set the system.

Enter S/N, check code, license, create time, customer full name, contact number, address, and click the save button. If you are an Australian installer, you will need to fill in the Street (NMI), Suburb (NMI) and Postcode (NMI) fields and add a new Region field, which has six fixed options (NSW, QLD, VIC, SA, TAS, WA). If SA is selected for Region, two more fields are added which are Agent and NMI.

Fields that are not marked "optional" need to be filled in.
Click "Next" to go to the installation steps interface.

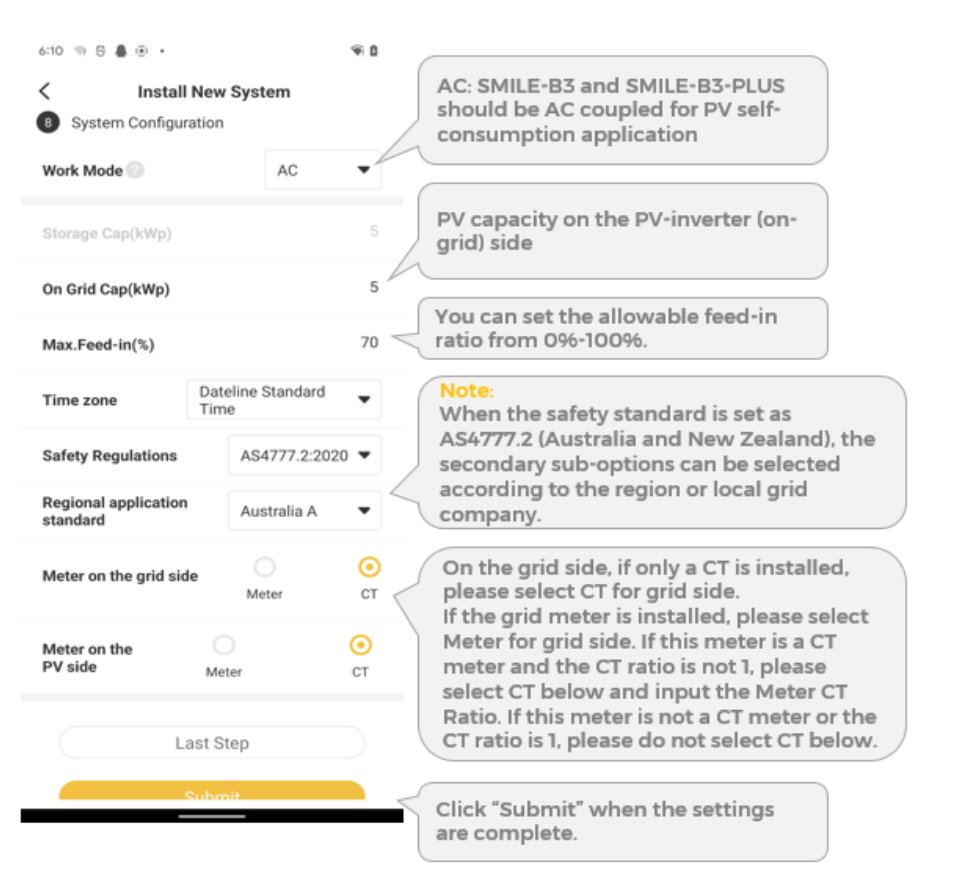
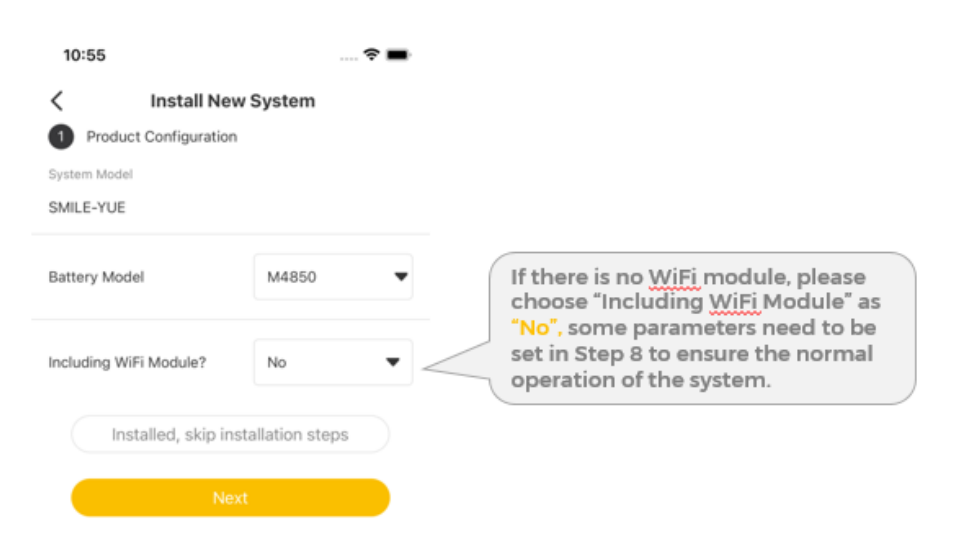

NOTICE

The safety standard must be set correctly

If you select a safety standard which is not valid for your country and purpose, it can cause a disturbance in the energy storage system and lead to problems with the grid operator. When selecting the safety standard, you must always observe the locally applicable standards and directives as well as the properties of the PV system (e.g. PV system size, grid-connection point).

- If you are not sure which safety standard is valid for your country or purpose, contact your grid operator for information on which safety standard is to be configured.

If there is a WiFi module, please choose "Including WiFi Module" as "Yes", the APP will jump to the WiFi configuration page, and please refer to section 9.3.

7.2. Register on AlphaCoud

7.2.1. Register as Installer Account

You can create a new account on our webserver for the normal monitoring. In addition, a part of our warranty is based on this connection to our webserver. The data produced prior to registration can be synchronized to the webserver.

Step1: Please use the following steps: Open the portal: www.alphaess.com.

Step2: Please fill in "Username", "Password" and click "Login" if you have already registered.

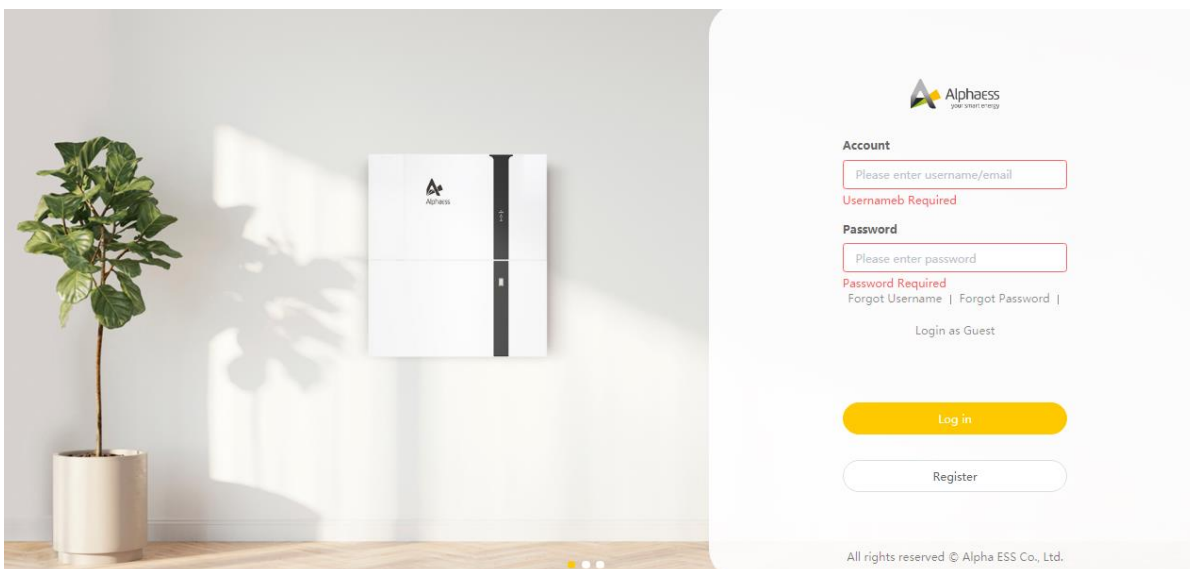

If not, please register by filling in the following web form;

User registration

* User Type: End user (dropdown)

* SN: Please enter system SN

* SN check code: Please enter the SN che

* Username: someone@example.com

* Zip Code: Please enter your zip code

* Password: Please enter the password

* Confirm Password: Please confirm the password

Language: English (dropdown)

* Contact Person: Please enter a contact

* Country / Region: Please select your coun (dropdown)

Province/State: Please select your provin (dropdown)

City/Town: Please select your city (dropdown)

Address: Please enter your address

Contact Number: Please enter your phone number

* Time Zone: Please select a time zone (dropdown)

* Installation Time: Please select an installation date (calendar)

Whether to allow automatic update (the automatic upgrade function is to actively update the latest push program to improve the use of the device when the system is online.)

Agree to the above terms [《Terms and Conditions》](#) and [《Privacy Policy》](#)

In this form, all fields with a red star are compulsory, and you can select the finally users or installation procedures.

***Serial number:** EMS serial number (please see the nameplate of the inverter)

***Username:** 5-15 letters / numbers

***Password:** 5-15 letters / numbers / characters

More details are available in the Online Monitoring Web Sever Installers User Manual, which can be downloaded from AlphaESS homepage.

7.2.2. Install New System

Installers who haven't yet registered need to click "Register" to visit the registration page. Please refer to "AlphaCloud Online Monitoring Webserver Installers User Manual", which you can get from AlphaESS sales and get license number from relevant sales from Alpha ESS.

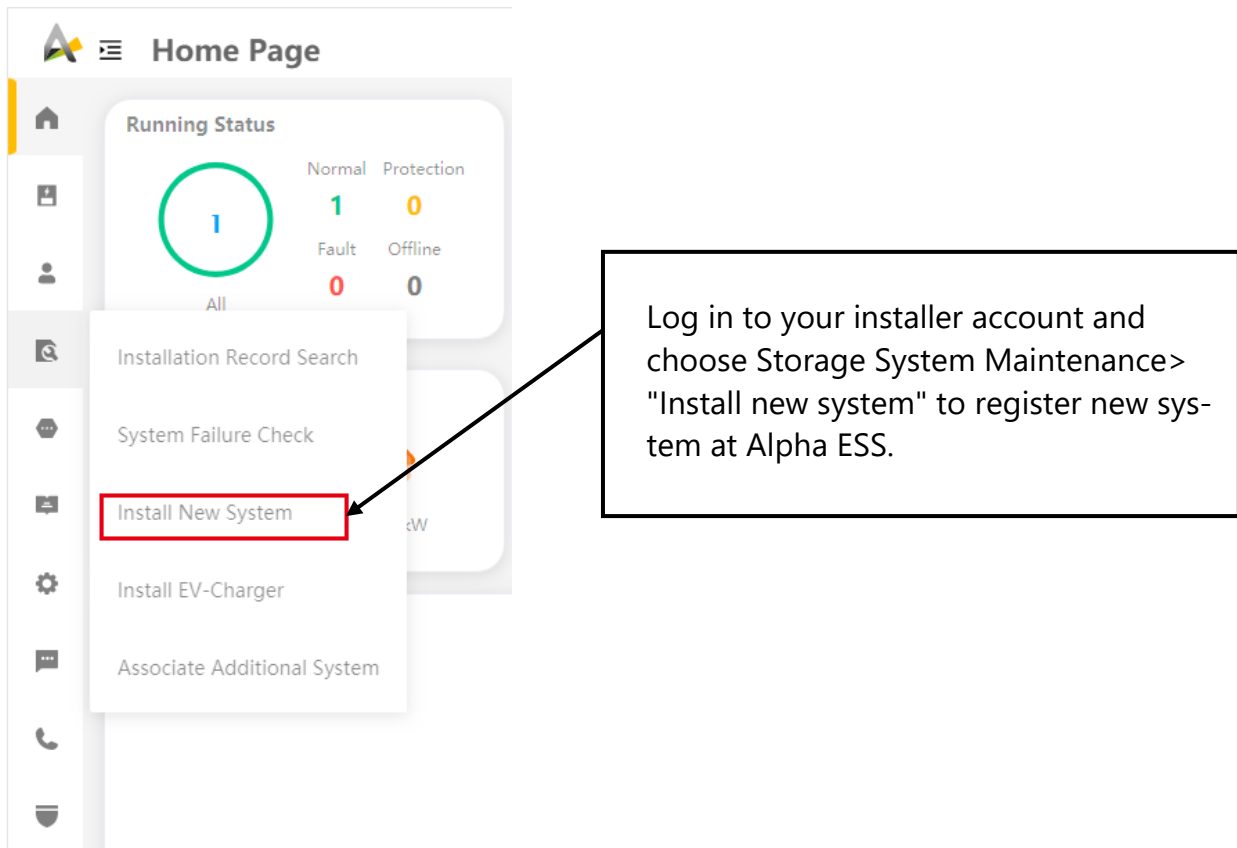

The screenshot shows the 'Home Page' dashboard. A sidebar menu on the left contains several options, with 'Install New System' highlighted by a red rectangular box. A callout box with a black border and white background points to this menu item. The text inside the callout box reads: 'Log in to your installer account and choose Storage System Maintenance > "Install new system" to register new system at Alpha ESS.'

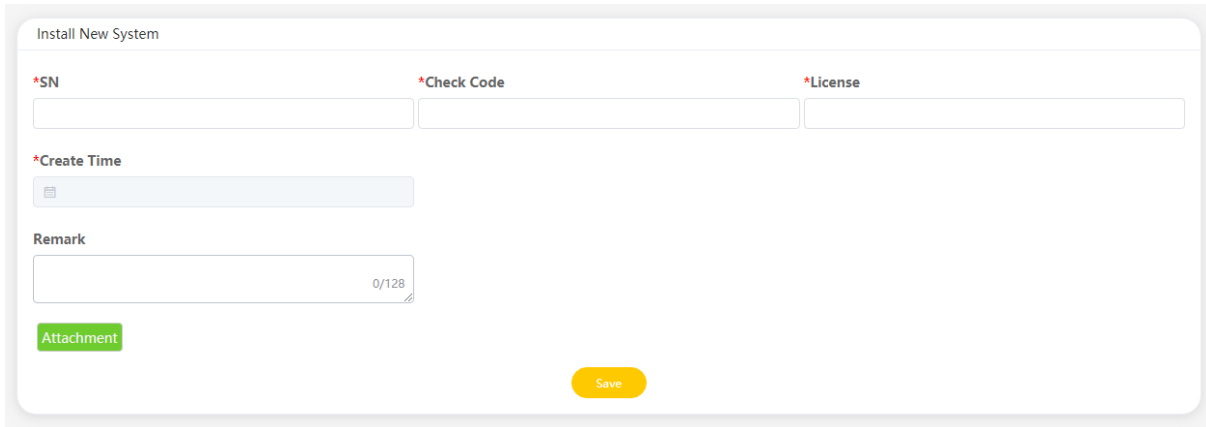

The screenshot shows the 'Install New System' form. It contains the following fields and buttons:

- *SN: A text input field.
- *Check Code: A text input field.
- *License: A text input field.
- *Create Time: A date/time picker.
- Remark: A text area with a character count of 0/128.
- Attachment: A green button with a document icon.
- Save: A yellow button.

Enter the system S/N, check code, license, installation date and click the save button. The red * in front of it is required. Click the Browse button to select the attachment you want to add.

8. Powering On and Off the System

8.1. Powering on the System

- 1) Switch on the battery breaker of the batteries.
- 2) Switch on the battery breaker which is at the bottom of the SMILE-G3-INV.
- 3) Press the battery button, if there are more than one battery, the button for each battery should be pressed within 5s of the previous one.
- 4) Switch on the AC breaker between the grid port of the SMILE-G3-INV and the grid.
- 5) Switch on the AC breaker between the backup port of the SMILE-G3-INV and the loads.
- 6) Switch on the PV switch at the bottom of the SMILE-G3-INV if there is any.
- 7) Switch on the AC breaker (if there is any) between the PV-inverter and the grid.

8.2. Powering off the System



WARNING

After the energy storage system is powered off, the remaining electricity and heat may still cause electric shocks and body burns. Therefore, put on protective gloves and operate the product 5 minutes after the power-off.

Procedure

- 1) Switch off the AC breaker between the SMILE-G3-INV and the load.
- 2) Switch off the AC breaker between the SMILE-G3-INV and the grid.
- 3) Switch off the PV switch at the bottom of the SMILE-G3-INV if there is any.
- 4) Switch off the PV switch between the PV string and the SMILE-G3-INV if there is any.
- 5) Switch off the battery breaker which is at the bottom of the SMILE-G3-INV.
- 6) Long press 5s the power button of the battery.
- 7) Switch off the battery breaker of the battery.

9. COMMISSIONING

9.1. Checking Before Power-On

No.	Check Item	Acceptance Criteria
1	Mounting environment	The mounting space is proper, and the mounting environment is clean and tidy, without foreign objects.
2	Battery pack and inverter mounting	The battery pack and inverter are mounted correctly, securely, and reliably.
3	WiFi mounting	The WiFi module is mounted correctly, securely, and reliably.
4	Cable layout	Cables are routed properly as required by the customer.
5	Cable tie	Cable ties are secured evenly and no burr exists.
6	Grounding	The ground cable is connected correctly, securely, and reliably.
7	Switch and breakers status	The PV switch (if there is any) and battery breakers and all the breakers connecting to the product are OFF.
8	Cable connections	The AC cables, PV cables (if there is any), battery power cables, and communication cables are connected correctly, securely, and reliably.
9	Unused power terminals	Unused power ports and communication ports are blocked by watertight caps.

9.2. Powering on the System and Install the Battery and inverter plastic decorative

Powering on the System

- Check the voltage range and frequency range of the grid and the installation of CT(s) or meter(s).
- Switch on the battery breaker of the battery.
- Switch on the battery breaker located on the energy storage inverter.
- Switch on the external AC breaker between the grid and the energy storage inverter.

- Firstly, don't press the battery button, don't switch on the PV switch on the energy storage inverter and don't switch on the AC breaker on the PV inverter if there is any.

Install the right plastic decorative of the Battery

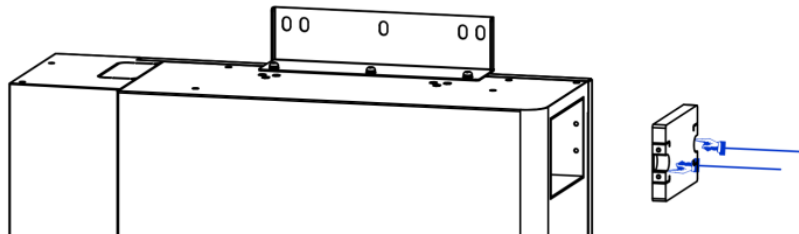

Install the right plastic decorative of the inverter

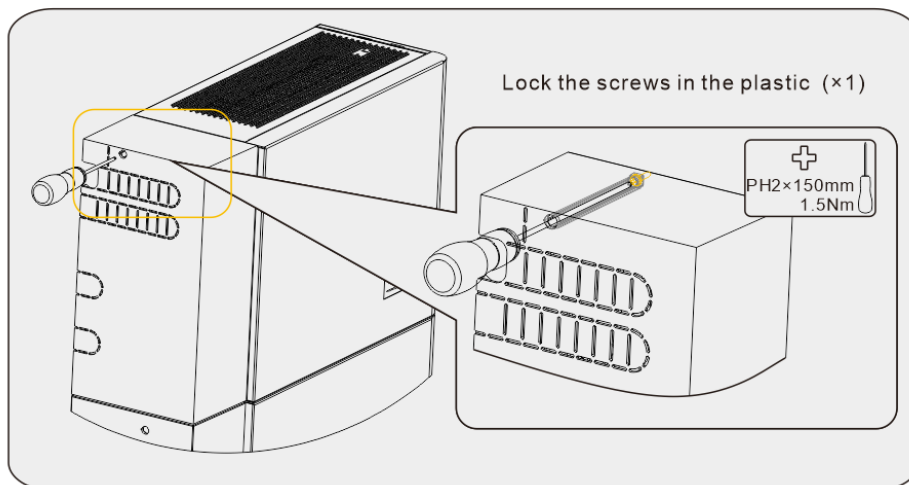
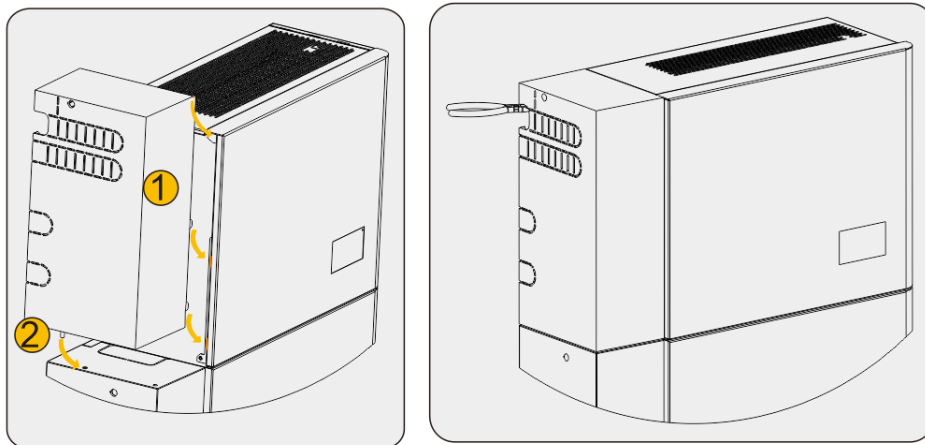

9.3. WiFi Module Configuration and Parameter Settings

9.3.1. WiFi Configuration

This section is for users who have an energy storage system with a WiFi module.

AlphaESS App is able to configure the network, set system basic parameter, monitor system operation status and check configuration information.

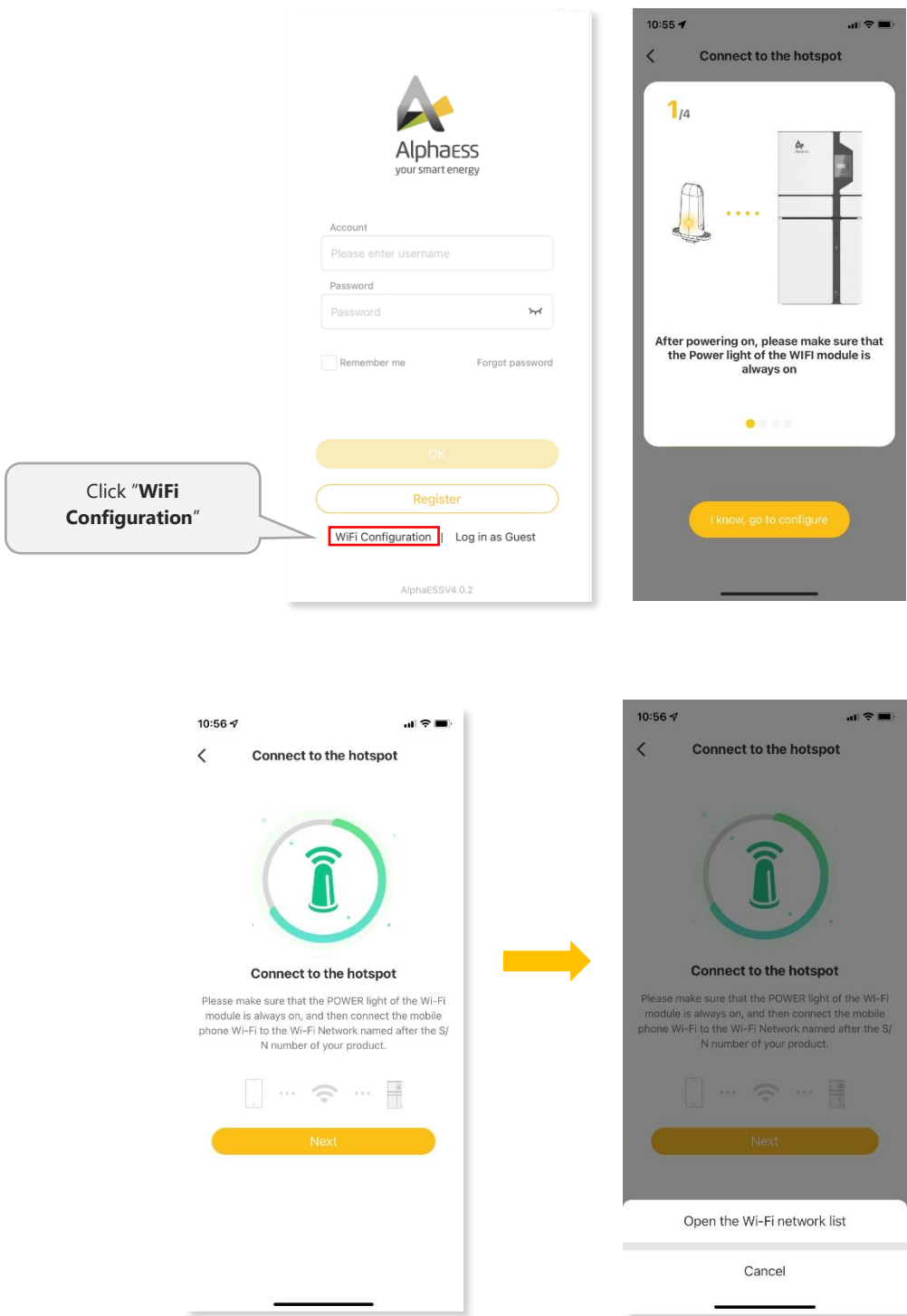

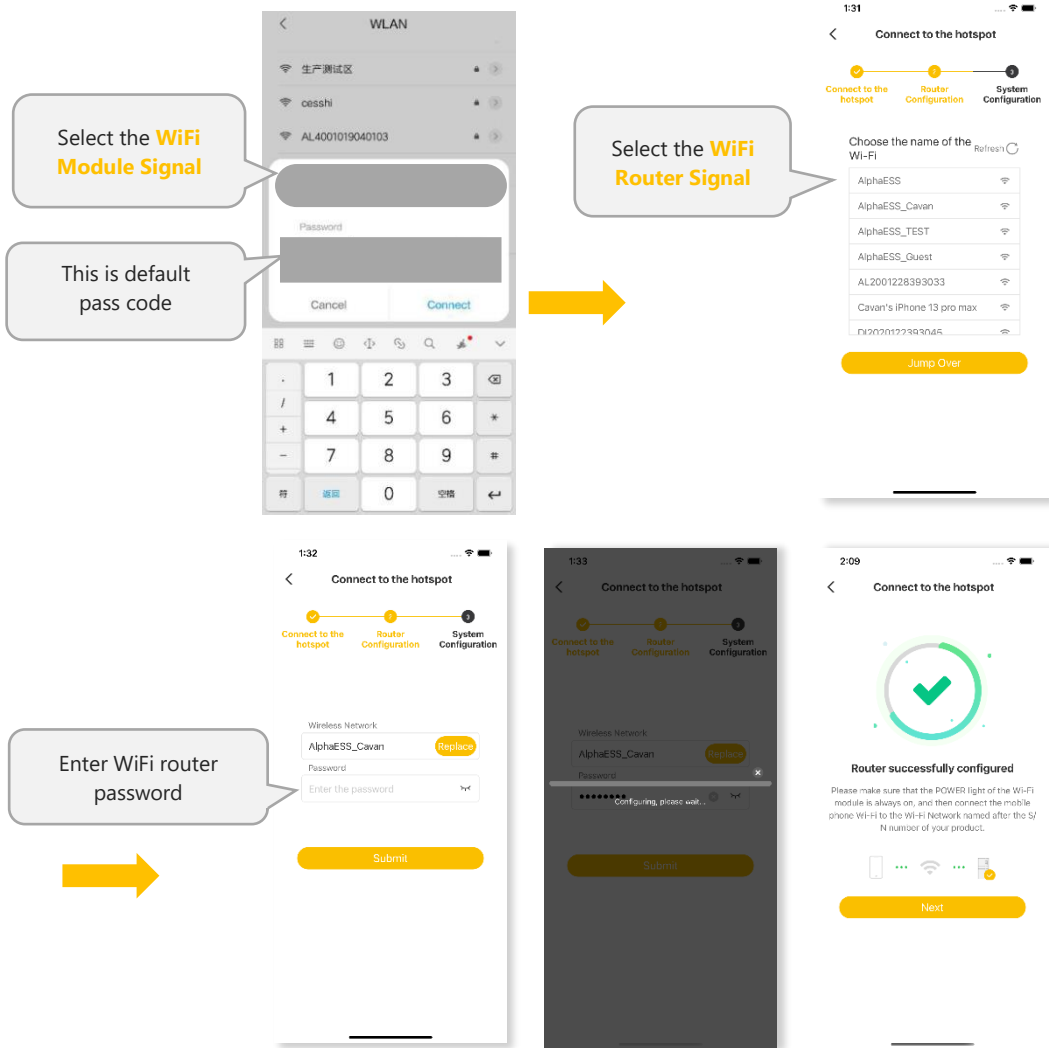

NOTE

The system will not be able to connect to the internet without WiFi configuration.

9.3.1.1 Basic Parameters Settings

DC Mode

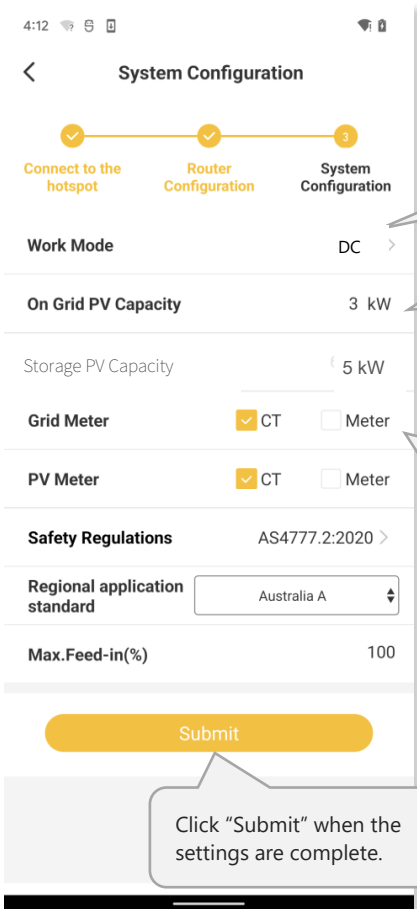
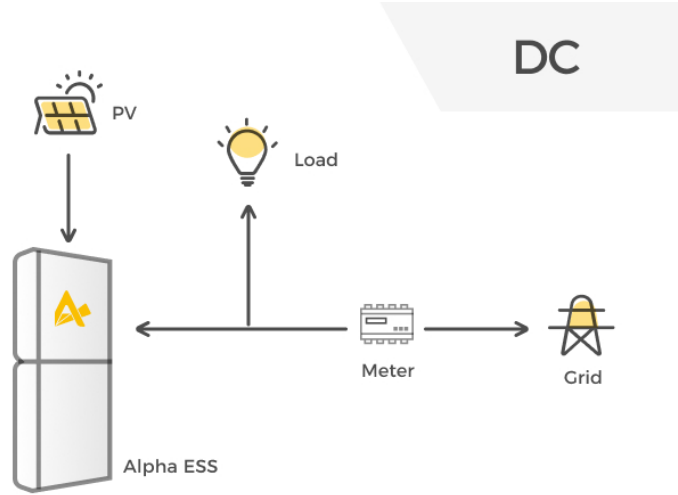

Three mode options: **DC**/AC/Hybrid

Storage PV capacity: PV capacity on the energy storage inverter side

On the grid side, if only a CT is installed, please select CT for grid side. If the grid meter is installed, please select Meter for grid side. If this meter is a CT meter and the CT ratio is not 1, please select CT below and input the Meter CT Ratio. If this meter is not a CT meter or the CT ratio is 1, please do not select CT below

Note: When the safety standard is set as AS4777.2 (Australia and New Zealand), the secondary sub-options can be selected according to the region or local grid companv.

You can set the allowable feed-in ratio from 0%-100%.

AC Mode

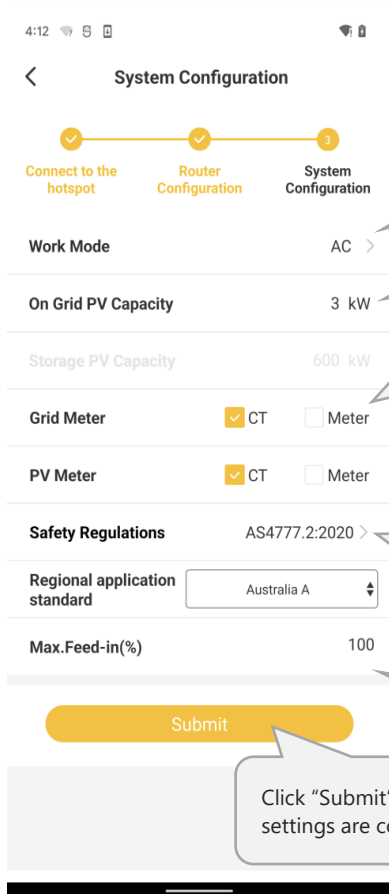
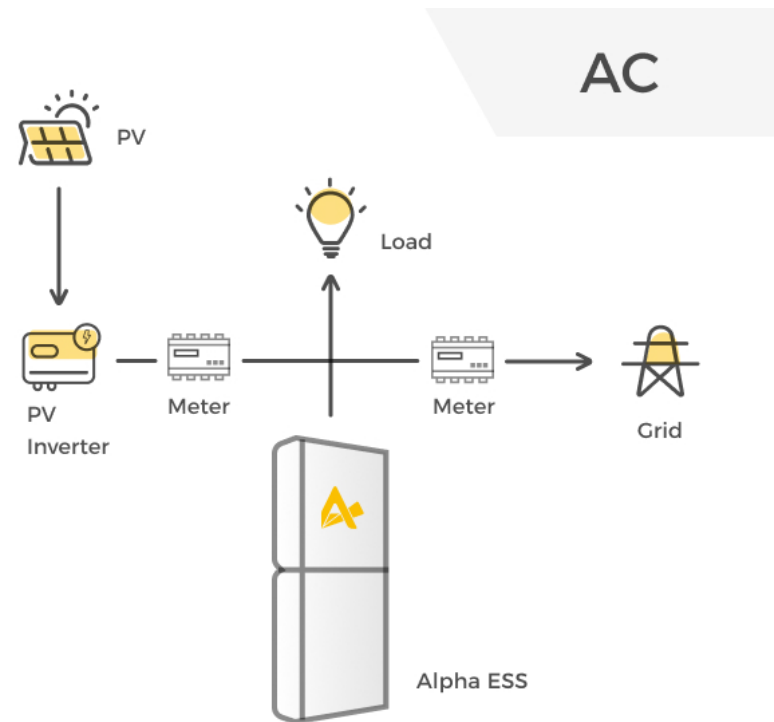

Three mode options: DC/AC/Hybrid

PV capacity on the PV-inverter (on-grid) side

On the grid side, if only a CT is installed, please select CT for grid side. If the grid meter is installed, please select Meter for grid side. If this meter is a CT meter and the CT ratio is not 1, please select CT below and input the Meter CT Ratio. If this meter is not a CT meter or the CT ratio is 1, please do not select CT below.

Note: When the safety standard is set as AS4777.2 (Australia and New Zealand), the secondary sub-options can be selected according to the region or local grid company.

You can set the allowable feed-in ratio from 0%-100%.

Click "Submit" when the settings are complete.

Hybrid Mode

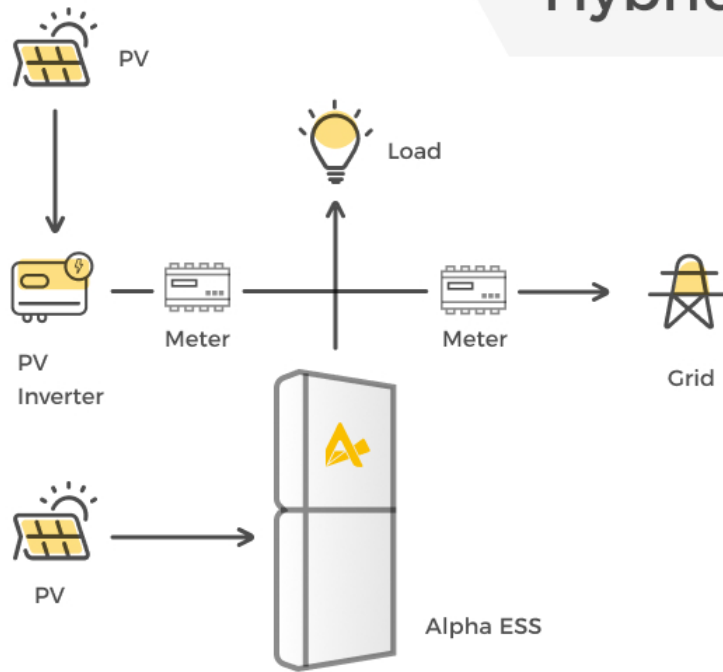

Hybrid

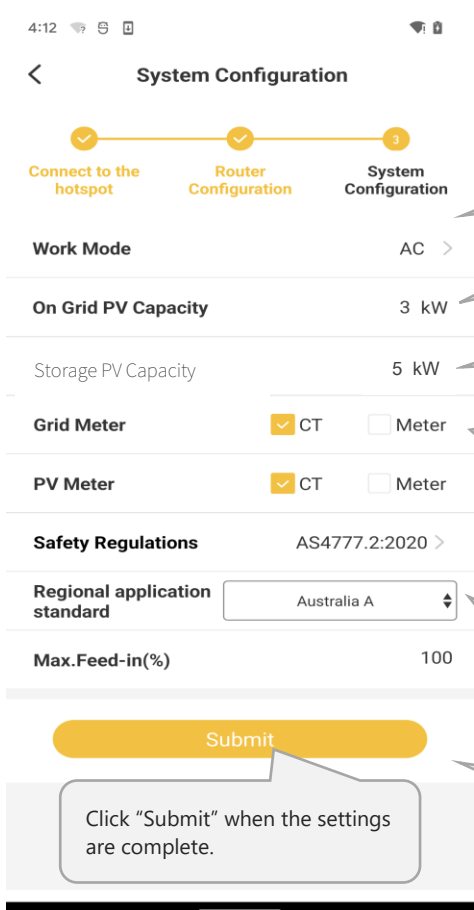

Three mode options: DC/AC/**Hybrid**

PV capacity on the PV-inverter (on-grid) side

Storage PV capacity: PV capacity on the energy storage inverter side

On the grid side, if only a CT is installed, please select CT for grid side.
If the grid meter is installed, please select Meter for grid side. If this meter is a CT meter and the CT ratio is not 1, please select CT below and input the Meter CT Ratio. If this meter is not a CT meter or the

Note:
When the safety standard is set as AS4777.2 (Australia and New Zealand), the secondary sub-options can be selected according to the region or local grid company.

You can set the allowable feed-in ratio from 0%-100%.

 NOTICE

The safety standard must be set correctly

If you select a safety standard which is not valid for your country and purpose, it will cause a disturbance in the energy storage system and lead to problems with the grid operator. When selecting the safety standard, you must always observe the locally applicable standards and directives as well as the properties of the PV system (e.g. PV system size, grid-connection point).

- If you are not sure which safety standard is valid for your country or purpose, please contact your grid operator for information on which safety standard is to be configured.

9.3.2. Direct Commissioning on WiFi configuration

You can commission the system during the WiFi configuration process directly.

9.3.2.1 Check the Running State without PV and Battery

- Keep the PV switch of the energy storage inverter and AC breaker of the PV-inverter off. Don't power on the batteries.
- Turn on some larger loads directly connected on the grid to check the grid status, the inverter LED ("Fault or SYS") will be red, don't worry, because the battery is not communicated. The grid power should be positive. Otherwise please check the direction of grid CT or grid meter installation.

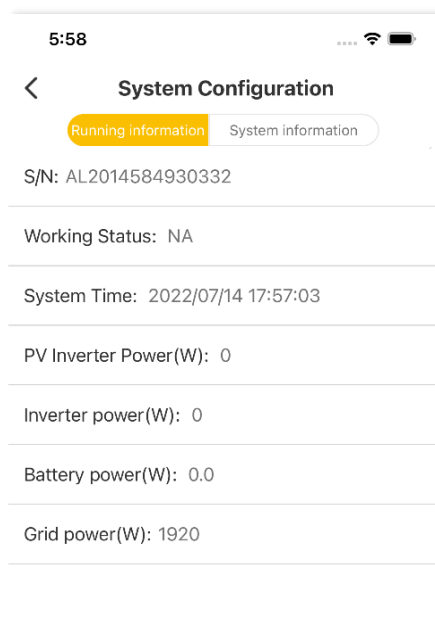

9.3.2.2 Check the Running State of PV and Battery

- Switch off the AC breaker between the grid port on the energy storage inverter and the grid, and switch off the AC breaker between the backup port on the energy storage inverter and the loads.
- Press the battery button. If there are more than one battery, press the button of each battery and the interval time of powering on any two batteries should be less than 5s.
- Switch on the AC breaker between the grid port of the energy storage inverter and the grid.
- Switch on the PV switch on the energy storage inverter if there is any and AC breaker on the PV-inverter if there is any.
- Switch off all the loads to see the battery charging status and the inverter LED ("Normal" or "SYS") will be solid on Green or White. Battery power value should be negative. If the system is in AC or hybrid mode, the PV inverter power value should be positive. If it is not normal, please check the direction of PV CT or PV meter installed.

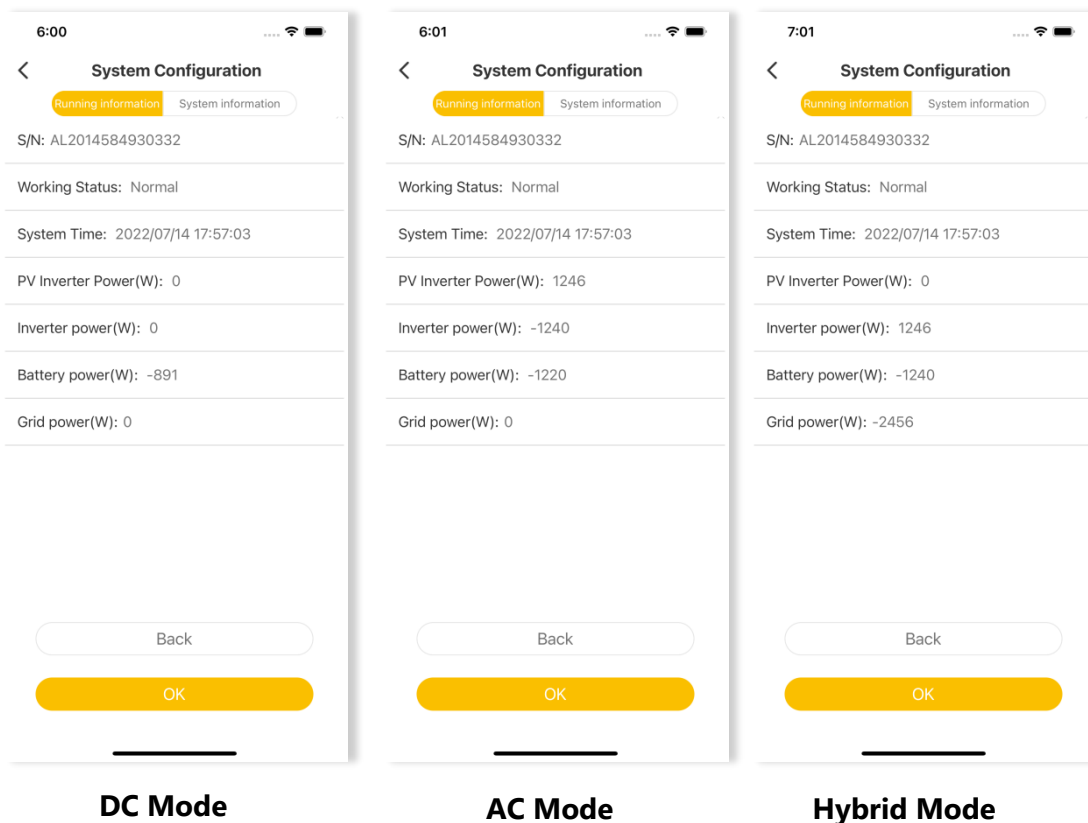

9.3.2.3 Check the UPS State

- Please connect an essential electrical appliance to the socket of backup load. Or switch on an essential electrical appliance already connected on the backup load port of the inverter.
- Switch on the AC breaker on the backup port of the energy storage inverter.
- Switch off the external AC breaker between the grid and the energy storage inverter.
- The inverter will enter the UPS mode at once.
- If the electrical appliance on backup side can work normally, it means that the wiring of the backup has been connected correctly.

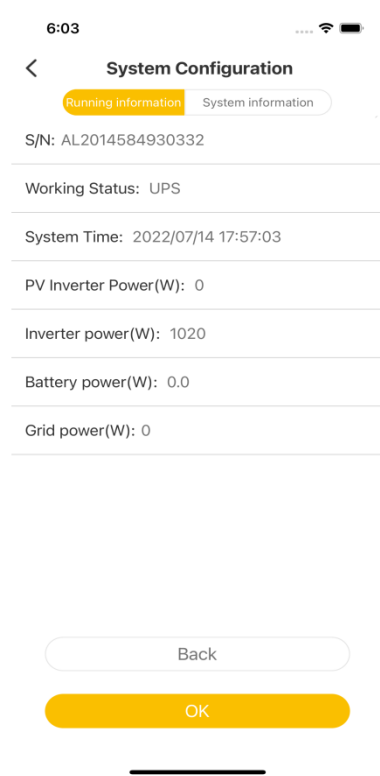

NOTICE

During commissioning, if the LED indicators on the display panel of the inverter or the battery pack show red, please refer to chapter troubleshooting.

9.4. Installing New System and Settings on the APP

9.4.1. Download and Install the APP



9.4.2. Register as an Installer

If you don't have an installer account, please register first.

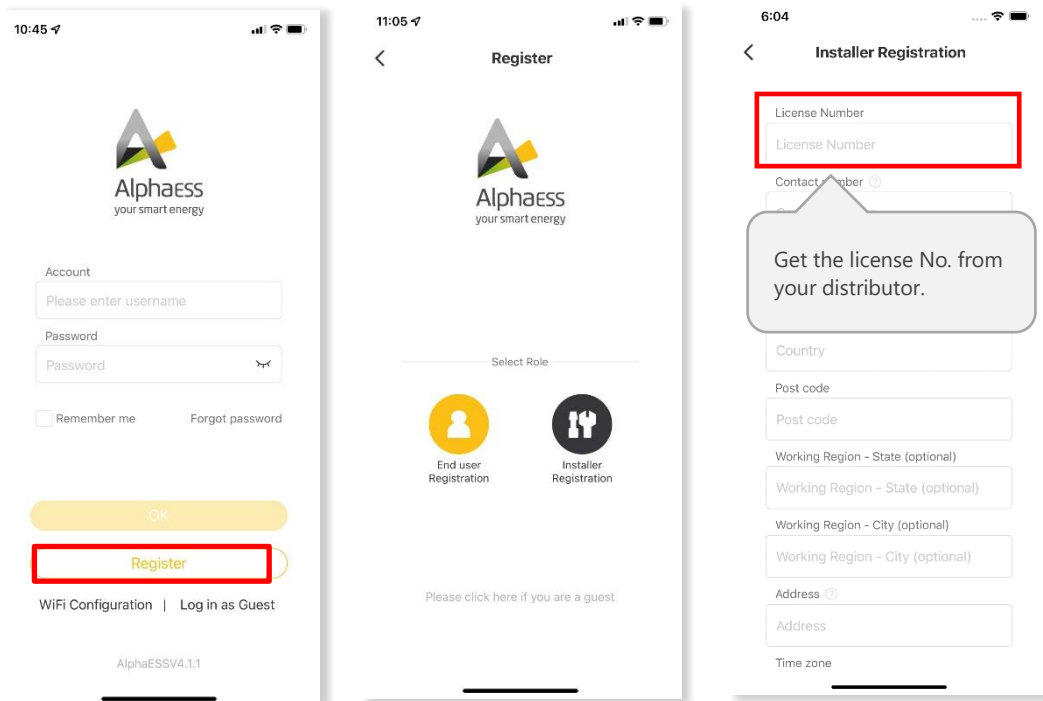

If you already have an installer account, please log in directly.

9.4.3. Install New System

If you have "installed" the new system already or want to install it later, please directly to the Section 9.3 WiFi Module Configuration and Parameter Settings. If not, you can "Install New System" first.

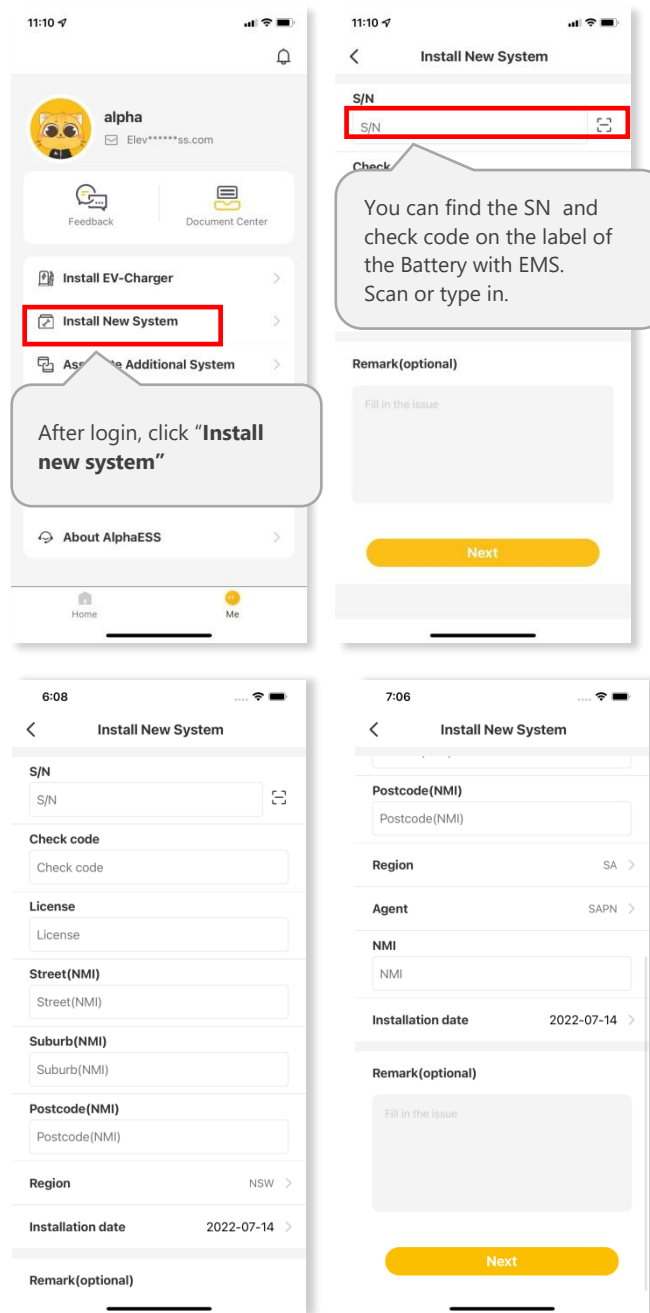

Australian Installer

Please enter your installer account and click "Install New System" to bind the system to your account and set the system.

Enter S/N, check code, license, create time, customer full name, contact number, address, and click the save button. If you are an Australian installer, you will need to fill in the Street (NMI), Suburb (NMI) and Postcode (NMI) fields and add a new Region field, which has six fixed options (NSW, QLD, VIC, SA, TAS, WA). If SA is selected for Region, two more fields are added which are Agent and NMI.

Fields that are not marked "optional" need to be filled in.

Click "Next" and go to Section 10.3 if the WiFi has not been configured.

9.5. Check the Running State On-line

If you have completed commissioning as described in section 10.3.2, please ignore this section.

You can also commission the system after WiFi configuration.

Please make sure the PV switch and battery breakers and all the breakers connecting to the product are ON.

9.5.1. Check the Charging Function of the Product

- To make sure the system is installed and operating correctly, please set the system to "Charging/Discharging Setting" by following the instructions below.

Step1

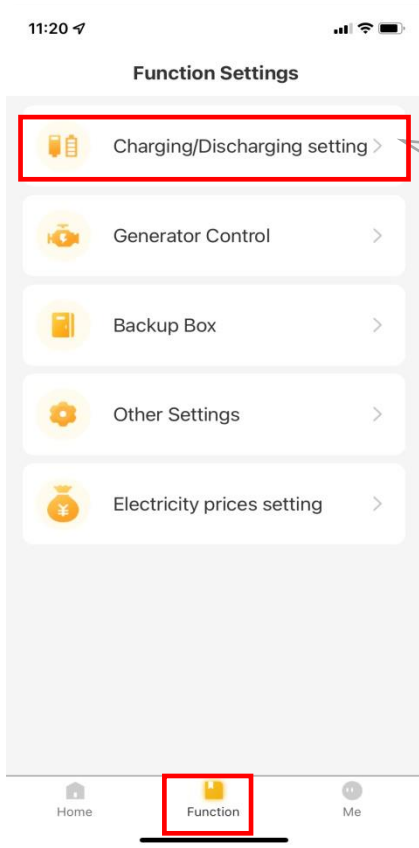

First click "**Function**" on the right-side bottom corner of the Home page.
Then click "**Charging and discharging setting**"

Step2

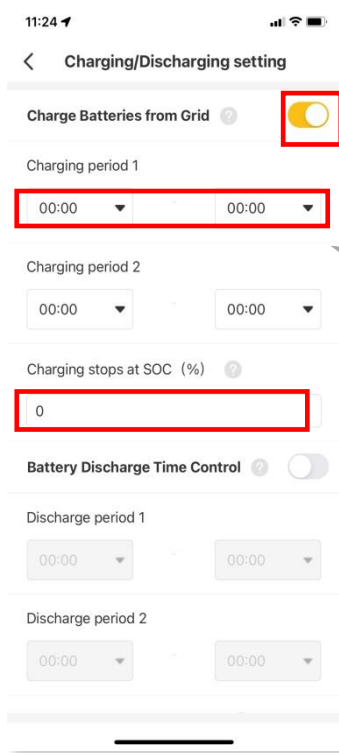

Select "ON" to Charge Batteries from Grid"

please set the "Charging period 1" for the time and the SOC would be **100** under this operation.

Step3

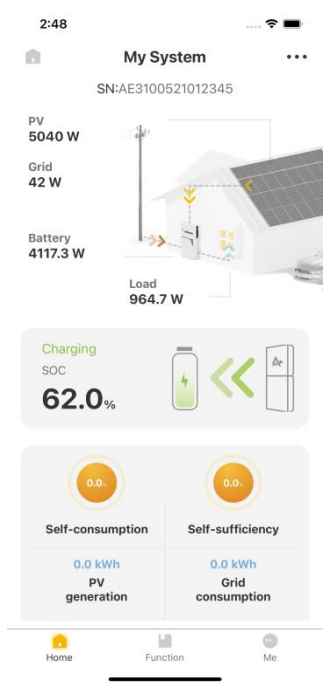

The relative value should be like this: $Load = PV \pm GRID - Battery$
 Battery should be in **charging** status. **PV arrow** should be as the picture shows. \pm : $>>$ absorbing from grid: +; $<<$ feed-in to grid:-
 If not correct, please check the CT or meter installed direction of both grid and PV side

- Check the running status of the system in "Step 3".
- If the operation is normal as described in "Step3", please remember to deactivate the "Charging/Discharging Setting" by clicking "OFF" and save the changes.

9.5.2. Check the PV Generation and Discharging Function of the Product

Step1: Please switch off the PV switch on the energy storage inverter and the AC breaker on the PV inverter if there is any. Switch on some larger loads to see the battery discharging status.



The relative value should be like this:
Load = GRID + Battery

Step 2: Please switch on the PV switch on the energy storage inverter and the AC breaker on the PV inverter if there is any. Check the running status of the system.



The relative value should be like this:
Load = PV ± GRID ± Battery
±: charging: - ; discharging: +
PV arrow should be as the picture shows.
±: >> absorbing from grid: +;
<< feed-in to grid:-
If not correct, please check the CT or meter installed direction on PV side

9.5.3. Check the UPS State of the Product

- Please connect an essential electrical appliance to the socket of backup load. Or switch on an essential electrical appliance already connected on the backup load port of the energy storage inverter.
- Switch on the AC breaker on the backup port of the energy storage inverter.
- Switch off the external AC breaker between the grid and the energy storage inverter.
- The product will enter the UPS mode at once.
- If the electrical appliance on backup side can work normally, it means that the wiring of the backup has been connected correctly.

 **NOTICE**

During commissioning, if the LED indicators on the display panel of the inverter or the battery pack show red, please refer to chapter troubleshooting.

9.5.3.1 Switch on all of the Breakers

Please don't forget to switch on all of the breakers.

9.6. Instruct the End User to Install the APP

Please make sure that your end user has downloaded the APP and registered the account correctly, and added the system SN.

10. Maintenance and Troubleshooting

10.1. Routine Maintenance

Normally, the energy storage system need no maintenance or calibration.

However, in order to maintain the accuracy of the SOC, it is recommended to perform a full charge calibration for SOC (charging battery until the charging power is 0) on the battery at regular intervals (such as two weeks).

Disconnect the system from all power sources before cleaning. Clean the housing, cover and display with a soft cloth.

To ensure that the energy storage system can operate properly in the long term, you are advised to perform routine maintenance on it as described in this chapter.

Maintenance checklist

Check Item	Acceptance Criteria	Maintenance Interval
Product cleanliness	The heatsink at the back of the product are free from obstacles or dust.	Once every 6 to 12 months
Product visible damage	The product are not damaged or deformed.	Once every 6 months
Product running status	<ol style="list-style-type: none"> The product operate with no abnormal sound. All parameters of the product are correctly set. Perform this check when the product is running. 	Once every 6 months
Electrical connections	<ol style="list-style-type: none"> Cables are securely connected. Cables are intact, and in particular, the cable jackets touching the metallic surface are not scratched. Unused cable glands are blocked by rubber sealing which are secured by pressure caps. 	<p>Perform the first maintenance 6 months after the initial commissioning.</p> <p>From then on, perform the maintenance once every 6 to 12 months.</p>

**CAUTION****Risk of burns due to hot heatsink and housing**

The heatsink and housing of the inverter can get hot during operation.

- During operation, do not touch any parts other than the cover.
- Wait approx. 30 minutes before cleaning until the heatsink has cooled down.

10.2. Troubleshooting

Inverter Error Troubleshooting

Error No.	Error description	Solution
100000	Grid_OVP	1. Check whether Grid is abnormal. 2. Confirm whether the grid cable connection is normal. 3. Restart inverter and check whether the fault is existing.
100001	Grid_UVP	
100002	Grid_OFP	
100003	Grid_UFP	
100005	BUS_OVP1	1. Check whether the input voltage of PV1 and PV2 exceeds 580V. 2. If the first one does not exist, restart the inverter to see if the fault still exists. If it still exists, please call the service center.
100007	Insulation_fault	1. Check whether PV cable connection is reliable. 2. Check whether PV cable is damaged.

100008	GFCI_fault	1. Restart inverter and check whether the fault is existing.
100009	Leakage current test failure	
100010	Grid_relay_fault	
100011	Over_Temperature	<ol style="list-style-type: none"> 1. Check whether the environment around inverter is with poor heat dissipation. 2. Confirm whether inverter installation meet the installation requirements.
100014	M_S_com_fault	Restart the inverter and check whether the fault is existing.
100017	MPPT1_OVP	Check the PV1 voltage. If it exceeds 585VDC, reduce the number of PV modules.
100018	MPPT1_SW_OCP	1. Try to reduce the PV power.
100019	MPPT1_HW_OCP	2. Restart the inverter to see if the fault still exists. If it still exists, please call the service center.
100020	MPPT1_OTP	<ol style="list-style-type: none"> 1. Try to lower the ambient temperature. 2. Make sure that the inverter is installed according to the manual and there is no shelter around the inverter. 3. After the inverter is powered off and waiting for 30 minutes, then restart it. If the fault still exists, please call the service center.
100021	MPPT2_OVP	Check the PV2 voltage. If it exceeds 585V, reduce the number of PV modules







100022	MPPT2_SW_OCP	1. Try to reduce the PV power.
100023	MPPT2_HW_OCP	2. Restart the inverter to see if the fault still exists. If it still exists, please call the service center.
100024	MPPT2_OTP	1. Try to lower the ambient temperature. 2. Make sure that the inverter is installed according to the manual and there is no shelter around the inverter. 3. After the inverter is powered off and waiting for 30 minutes, then restart it. If the fault still exists, please call the service center.
100025	BAT_OVP	Check whether the actual battery voltage exceeds the battery charging cut-off voltage by more than 20V.
100026	BAT_UVP	Check whether the actual battery voltage is lower than the battery discharge cut-off voltage.
100027	Battery_lose	Confirm that the wiring is normal, and check whether the battery voltage sampling value is less than 75V.
100028	BAT_OTP	1. Try to lower the ambient temperature. 2. Make sure that the inverter is installed according to the manual and there is no shelter around the inverter. 3. After the inverter is powered off and waiting for 30 minutes, then restart it. If the fault still exists, please call the service center.

100029	BAT1_charge_OCP	<ol style="list-style-type: none"> 1. Try to reduce battery power. 2. Restart the inverter to see if the fault still exists. If it still exists, please call the service center.
100030	BAT1_discharge_OCP	
100031	BAT2_charge_OCP	
100032	BAT2_discharge_OCP	
100033	BAT1_HW_OCP	
100034	BAT2_HW_OCP	
100035	INV_OTP	<ol style="list-style-type: none"> 1. Try to lower the ambient temperature. 2. Make sure that the inverter is installed according to the manual and there is no shelter around the inverter. 3. After the inverter is powered off and waiting for 30 minutes, then restart it. If the fault still exists, please call the service center.
100036	NV_OVP	The effective value of grid voltage exceeds the maximum protection value of national standard voltage.
100037	INV_UVP	<ol style="list-style-type: none"> 1. Whether the off grid output terminal is short circuited or has impact load. 2. Restart the inverter to see if the fault still exists. If it still exists, please call the service center.
100038	Output_DC_ over_current	Restart the inverter to see if the fault still exists. If it still exists, please call the service center.

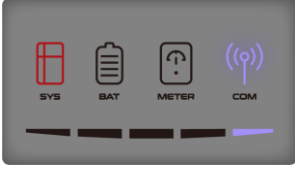
100039	INV_OCP	<p>1. Check whether the off grid output terminal is overloaded, short circuited or has impact load.</p> <p>2. Restart the inverter to see if the fault still exists. If it still exists, please call the service center.</p>
100040	INV_HW_OCP	<p>Restart the inverter to see if the fault still exists. If it still exists, please call the service center.</p>
100041	Output_DC_over_voltage	
100042	Output_short	<p>1. Use a multimeter to test the impedance of the off grid output. If it is small, check whether the wiring is correct.</p> <p>2. Restart the inverter to see if the fault still exists. If it still exists, please call the service center.</p>
100043	Output_overload	<p>1. Check whether the load exceeds the rated power.</p> <p>2. Restart the inverter to see if the fault still exists. If it still exists, please call the service center.</p>
110000	Bat over-voltage alarm	<p>Check that the actual battery voltage is 10V higher than the battery charging cut-off voltage</p>
110001	Bat under-voltage alarm	<p>Check that the actual battery voltage is 10V higher than the battery discharging cut-off voltage</p>
110002	output_overload_alarm	<p>Check whether the load exceeds 0.95 of the rated power</p>





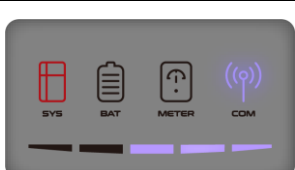
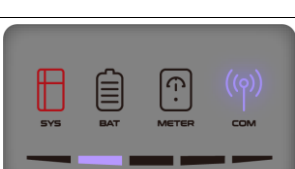

110003	abnormal_temperature_sensor	Restart the inverter to see if the fault still exists. If it still exists, please call the service center.
110004	dc_power_alarm	<ol style="list-style-type: none"> 1. Check whether the total power of the battery and PV is less than the load power. 2. Restart the inverter to see if the fault still exists. If it still exists, please call the service center.
110005	battery_stops_running_alarm	<ol style="list-style-type: none"> 1. If the battery is not connected, use a multimeter to measure whether there is voltage at the battery terminal. 2. Restart the inverter to see if the fault still exists. If it still exists, please call the service center.
110006	overtemperature_alarm	<ol style="list-style-type: none"> 1. Try to lower the ambient temperature. 2. Make sure that the inverter is installed according to the manual and there is no shelter around the machine. 3. After the inverter is powered off and waiting for 30 minutes, then restart it. If the fault still exists, please call the service center.

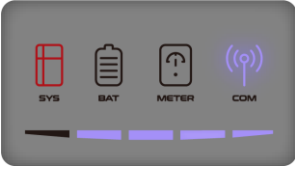

10.2.1. Inverter Protection Description

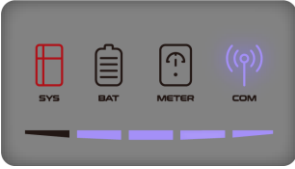
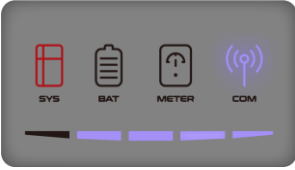
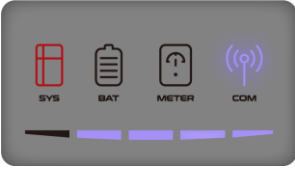
LED Indicator	Error Code	LED Display	Description	Troubleshooting
Inverter is faulty, SYS red light is on, BAT is off, METER is off, COM is on	1		DC-Group: Bus soft start failed	Wait for automatic recovery. If the problem is not solved yet, please call the service center.
	2		BUS_OVP1	
	2		Dc_bus_undervolt	
	3		Bus Short	
	4		INV Soft Timeout	
	5		INV_OVP	
	6		Output_short	
	7		Output_overload	Wait for automatic recovery. If the problem is not solved yet, please call the service center.
8		Grid Load Reverse		

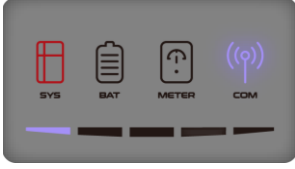
Inverter is faulty, SYS red light is on, BAT is off, METER is off, COM is on	8		LPE Reverse	
	9		EMSSCI	
	10		12V auxiliary power Fault	
	10		1.5V auxiliary power Fault	
	10		0.5V auxiliary power Fault	
	11		NTC Loss	
	12		BAT_UVP	
	12		BAT_OVP	
	13		Leakage current test failure	
	14		GFCI_fault	

Wait for automatic recovery.
If the problem is not solved yet, please call the service center.

<p>Inverter is faulty, SYS red light is on, BAT is off, METER is off, COM is on</p>	15		INV HCT Fault	<p>Wait for automatic recovery. If the problem is not solved yet, please call the service center.</p>
	15		Load CT Fault	
	15		PV1 CT Fault	
	15		PV2 CT Fault	
	15		Bat1 CT Fault	
	15		Bat2 CT Fault	
	16		Grid_relay_fault	
	16		Bypass Relay Fault	
	16		Load Relay Fault	
	16		NPE Relay Fault	

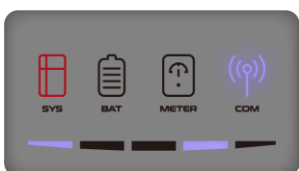
Inverter is faulty, SYS red light is on, BAT is off, METER is off, COM is on	14		Insulation_fault	Wait for automatic recovery. If the problem is not solved yet, please call the service center.
	14		DCI Consistency Failure	
	17		WatchDog	
	18		INV Open Loop	

 **NOTE**

1. the four LEDs in the first row are system (SYS), battery (BAT), meter (METER), and communication (COM);
2. The five LEDs in the second row are divided into two functions:
 - 1) Battery SOC power display;
 - 2) When a fault occurs, the corresponding fault code will be displayed. From right to left, the numbers represented by each light are 1, 2, 4, 8, 16.

10.2.2. Battery Protection Description









LED Indicator	Error Code	LED Display	Description	Troubleshooting
<p>Yellow LEDs on or Yellow LEDs flash once per second.</p>	1		Temperature difference	Wait for automatic recovery. If the problem is not solved yet, please call the service center.
	3		High-Temperature	Stop discharging and charging until this code is eliminated and wait for the temperature to drop.
	4		Low-temperature discharge	Stop discharging until this code is eliminated and wait for the temperature to rise
	5		Over-current charge	Wait for automatic recovery. If the problem is not solved yet, please call the service center.
	6		Over-current discharge	
	8		Cell overvoltage	
	9		Cell under voltage	Stop discharging and call the service immediately.
	11		Low-temperature charge	Stop discharging until this code is eliminated and wait for the temperature to rise.



NOTE

In the case of work mode, if the protection code 9 appears, please press the power

button of the battery 5 times within 10 seconds, the BMS will be forced to turn on the MOSFET of discharge so that the inverter can detect the battery open voltage and charge the battery.

10.2.3. Battery Error Description

LED Indicator	Error Code	LED Display	Description	Troubleshooting
Yellow LEDs on or Yellow LEDs flash once per second.	Error 01		Hardware error	Wait for automatic recovery. If the problem is not solved yet, please call the service center.
	Error 05		Hardware error	
	Error 06		Circuit breaker open	Switch on circuit breaker after powering off the battery.
	Error 08		LMU disconnect (slave)	Reconnect the BMS communication cable.
	Error 09		SN missing	Call for service.
	Error 10		LMU Disconnect (master)	Reconnect the BMS communication cable.
	Error 11		Software version inconsistent	Call for service.
	Error 12		Multi master	Restart all batteries.
	Error 13		MOS over temperature	Power off the battery and power on the battery after 30 minutes.

	Error 14		Insulation fault	Restart battery and in case the problem is not resolved, call for service.
	Error 15		Total voltage fault	Restart battery and in case the problem is not resolved, call for service.

! NOTE
 In the case of work mode, if the protection code 09 appears, please press the power button 5 times within 10 seconds, the BMS will be forced to turn on the MOSFET of discharge so that the inverter can detect the battery open voltage and charge the battery.

11. Uninstallation & Return

11.1. Removing the Product

Procedure

- Step 1: Power off the energy storage system by following instructions in Chapter 8.2 Powering Off the System.
- Step 2: Disconnect all cables from the product, including communication cables, PV power cables, battery power cables, AC cables, and PE cables.
- Step 3: Remove the WiFi module.
- Step 4: Remove the product from the wall bracket. Remove the expansion battery from the wall bracket.
- Step 5: Remove the wall brackets.

11.2. Packing the Product

If the original packaging is available, put the product inside it and then seal it using adhesive tape.

If the original packaging is not available, put the product inside a suitable cardboard box and seal it properly.

11.3. Disposing of the Product

- If the product service life expires, dispose of it according to the local disposal rules for electrical equipment and electronic component waste.
- Dispose of the packaging and replaced parts according to the rules at the installation site where the device is installed.
- Do not dispose the product with normal domestic waste.



12. Specification

12.1. Datasheet of Inverter SMILE-G3-INV

Item	SMILE-G3-S5-INV	SMILE-G3-S3.6-INV	SMILE-G3-B5-INV
Input DC (PV side)			
Recommended max. PV power	10000	7200	NA
Max. PV input voltage	580 V		NA
Rated voltage	360 V		NA
Start-up voltage	90 V		NA
MPPT voltage range	100 ~ 550 V		NA
Max. Input Current Per MPPT	15 A / 15 A		NA
Max. Short Circuit Current Per MPPT	18.75 A / 18.75 A		NA
MPPT Number	2		NA
Max Input Strings Number Per MPPT	1		NA
Battery			
Battery Type	Li-ion		
Battery Voltage Range	80 ~ 450 V		
Maximum Charging Power	5 kW		

Maximum Charge/ discharge current	60 A / 60 A		
Communication	CAN		
Output AC (Back-up)			
Rated output power	5 kW	3.68 kW	5 kW
Max Apparent Output Power	5 kVA	3.68 kVA	5 kVA
Back-up switch time	<20 ms		
Rated output voltage	L/N/PE, 230 V		
Rated Frequency	50/60 Hz		
Rated output current	21.7 A	15.7 A	21.7 A
THDv(@linear load)	3%		
Input AC (Grid side)			
Rated Output Current	L/N/PE, 230 V		
Rated Frequency	50/60 Hz		
Rated Input Power	10 kW	7.2kW	10 kW
Max. input current	43.5 A	31.3A	43.5 A
Output AC(Grid side)			

Rated output power	5 kW	3.68 kW	5 kW
Max. Apparent Output Power	5 kVA	3.68 kVA	5 kVA
Operation Phase	Single phase		
Rated Grid Voltage	L/N/PE, 230 V		
Grid Voltage Range	180 ~ 270 V		
Rated Grid Frequency	50 / 60 Hz		
Rating Grid Output Current	21.7 A	15.7 A	21.7 A
Power Factor	>0.99 (0.8 leading - 0.8 lagging)		
Thdi	< 3%		
Protection Class	I		
Overvoltage Category	III		
Efficiency			
Max Efficiency	>97%		
EU Efficiency	>96.2%		
Protection			
Anti-Islanding Protection	Integrated		
Insulation Resistor Detection	Integrated		

Residual Current Monitoring Unit	Integrated
Output Over Current Protection	Integrated
Output Short Protection	Integrated
Output Overvoltage Protection	Integrated
DC Reverse Polarity Protection	Integrated
PV Overvoltage Protection	Integrated
PV Switch	Integrated
Battery Breaker	Integrated
General data	
Dimensions (W*H*D)	610*212*366 mm
Weight	19.5kg
Topology	Transformerless
Operation Temperature Range	-25 ~ +60 °C
Ingress Protection	IP65
Noise Emission	<30 dB(A) @1m

Cooling Concept	Natural convection
Max. Operation Altitude	3000 m
Grid Connection Standard	G98/G99, VDE-AR-N 4105, EN 50549-1, VDE 0126, RD 1699, CEI0-21, C10/11, NRS 097-2-1, Tor Erzeuger, MEA, PEA, AS/NZW 4777.2, IEEE1547
Safety/ EMC Standard	IEC62040-1, IEC62109-1/-2.AS3100, NB/T 32004, EN61000-6-2, EN61000-6-3
Features	
PV Connection	Vaconn H4 connectors/MC4 (optional)
Grid Connection	Vaconn
Back-up Connection	connectors
BAT Connection	connectors
Communication	LAN, WiFi (optional)
Warranty	5 years standard

12.2. Datasheet of Battery

Model	SMILE-G3-BAT-10.1P
Battery type	LFP (LiFePO4)
Weight	90 kg
Dimension (W*D*H)	610 * 210 * 790 mm
Ingress protection	IP65
Energy capacity	10.1 kWh
Usable capacity	9.6 kWh
DoD	95%
Nominal voltage	96 V
Operating voltage range	90 ~ 108 V
Max. Charging / discharging current *	60 A
Operating temperature range	Charge: $0 < T < 50^{\circ}\text{C}$ / Discharge: $-10 < T < 50^{\circ}\text{C}$
Monitoring parameters	System voltage, current, cell voltage, cell temperature, PCBA temperature
BMS communication	CAN
System	
Safety	IEC62619/ IEC63056/IEC62040
Warranty	5 Year product warranty, 10 Year performance warranty
Transportation	UN38.3

* Max. charge/discharge current derating will occur related to temperature and SOC.

Appendix 1: System Overview

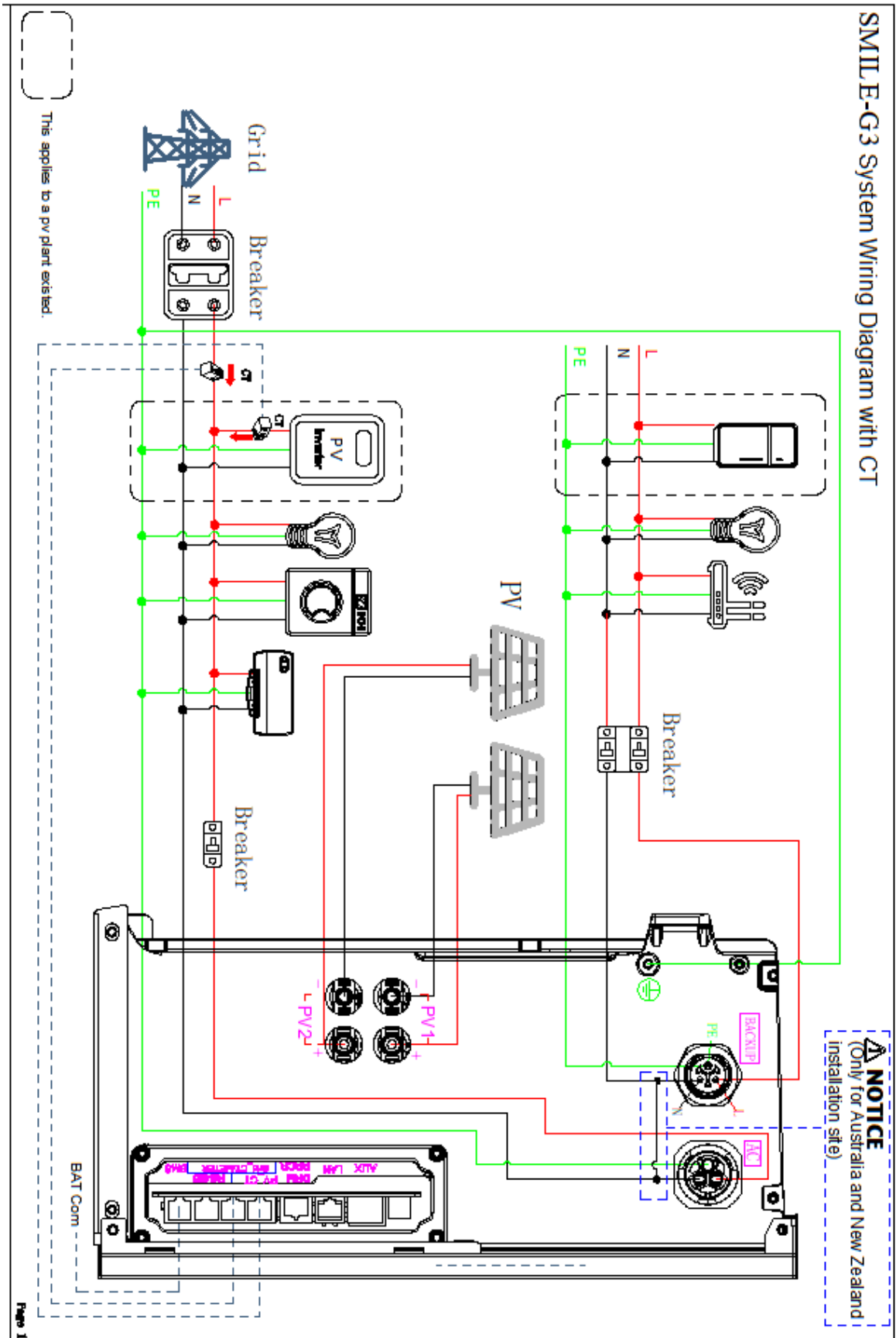



13. Appendix 2: Regional Application Standard

Please check with your local grid company and choose the correspond Regional Application Standard, the power quality modes Volt-var and Volt-Watt will be running automatically. (Only for regions with AS/NZW 4777.2 safety regulations).

Regional application Standard	Electric Company
Australia A	N/A
Australia B	N/A
Australia C	N/A
New Zealand	N/A
Vector	New Zealand Vector

 @AlphaEnergyStorageSystem  @AlphaESS  @alpha_ess  @AlphaESS  www.alphaess.com

Alpha ESS Co., Ltd.

 +86 513 8060 6891
 info@alpha-ess.com
 www.alphaess.com
 Jiuhua Road 888, Nantong High-Tech Industrial Development Zone, Nantong City, 226300

Alpha ESS Suzhou Co., Ltd.

 +86 512 6828 7609
 info@alpha-ess.com
 www.alphaess.com
 Building 10-A, Canal Town Industrial Park, 99 Taihu E Rd, Wuzhong District, Suzhou 215000

Alpha ESS Europe GmbH

 +49 610 3459 1601
 europe@alpha-ess.de
 www.alphaess.de
 Paul-Ehrlich-Straße 1a, D-63225 Langen, Hessen



Alpha ESS Australia Pty. Ltd.

 +61 402 500 520 (Sales)
+61 1300 968 933 (Technical Support)
 info@alpha-ess.com
 www.alphaess.com



Alpha ESS Italy S.r.l.

 +39 339 462 4288
 info@alpha-ess.it
 www.alphaess.com
Via Don Minzoni, 17, Calenzano Firenze 50041



Alpha ESS Korea Co., Ltd

 info@alpha-ess.com
 2F, 19-4, Nohyeong 11-gil, Jeju-si, Jeju-do, Republic of Korea



Alpha ESS UK Co., Ltd

 +44 145 354 5222
 info@alpha-ess.com
 Drake House, Long Street, Dursley, gl11 4hh

Alpha ESS International Pte. Ltd.

 +65 6513 1125 / +65 6513 1126
 Singapore@alpha-ess.com
 2 Corporation Road #01-06A Corporation Place Singapore 618494

Alpha ESS USA, Inc.

 +1 408 368 7828
 usa@alpha-ess.com
 Unit 5 2180 S Ivanhoe St, Denver, CO 80222