

● YOUR
● SMART
● ENERGY



STORION H30

COMMERCIAL &
INDUSTRIAL SERIES

POWER

30 kW

CAPACITY

34.56 ~ 96.77 kWh



KEY FEATURES

- **Highly Integrated**

The cabinet contains batteries, PCS, DC/DC, and EMS, but only occupies a small area.

- **Quick Installation**

Backplug battery solution greatly reduces on-site installation time and risks.

- **Hybrid Input**

PV Input: 3*MPPT with 250V ~ 830V PV Voltage (MPPT 200 ~ 830V)

Battery Input: 150V ~ 750V (350V ~ 750V@full load), 0.25P ~ 1P Charging/Discharging

- **Multiple System Operation Monitoring**

Local SCADA Monitoring & Commercial and Industrial Cloud

STORION H30





System Functions

- Backup (Optional)
- Radio Ripple Control Receiver
- Peak Shaving and Load Shifting
- Timed Charge and Discharge

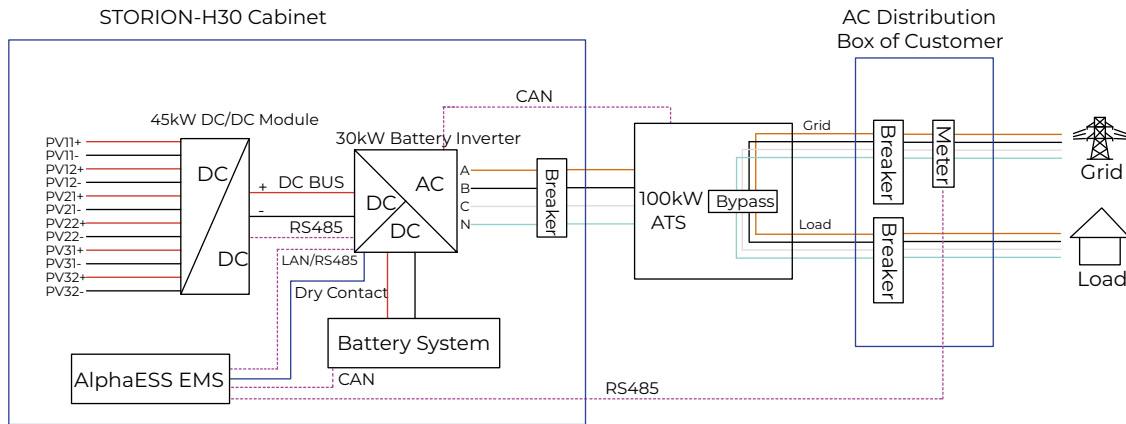
System Diagram



Battery Parameters

Item	Data		
Battery Module		M7790-S 1C	M38210-SC 0.5C
Battery Type		LiFePO4	LiFePO4
Pack		3.2 V / 90 Ah@1P24S	3.2 V / 105 Ah@2P12S
Internal Resistance		≤10 mΩ	≤10 mΩ
Nominal Capacity		6.912 kWh	8.064 kWh
Rated Voltage		76.8 V	38.4 V
Operating Voltage		72 V ~ 84.48 V	36 V ~ 43.2 V
Max. Charging/Discharging Current		90 A	105 A
System Cycle Life		80% EOL with 6000@1C 25°C	80% EOL with 6000@0.5C 25°C
Communication		CAN	CAN
Dimensions (W x D x H)		326 x 654 x 250 mm	325 x 658 x 232 mm
Weight		64 kg	64 kg
String Pack QTY		5 ~ 8	8 ~ 12
Certifications		IEC62619, IEC62477, UN38.3, IEC61000	IEC62619, UN38.3, IEC61000

PCS Parameters



30kW High Power Density
Bi-Directional Power
Conversion System
DC-Coupled Solution

Item	Data
Battery Voltage Range	150 V ~ 750 V (350 V ~ 750 V@full load)*
Max. Battery Current	90 A
Rated Output Power	30 kW
Rated Grid Voltage	3L / N / PE 400VAC±15%
Grid Frequency	50 / 60 Hz
AC PF	Listed: 0.8 ~ 1 leading or lagging Actual: 0.1 ~ 1 leading or lagging
Off-Grid Voltage	3L / N / PE 400VAC±15%
Off-Grid Frequency	50 / 60 Hz
Overload Capacity	110% ~ 120%, 10min; 120% ~ 150%, 200ms
Weight	33 kg

STORION H30



DC/DC Parameters



High Power Density
Bi-Directional DC-DC Converter
Modular Design

Item	Data
Rated Power	45 kW
PV Input Voltage Range	250 V ~ 830 V
Rated Input Voltage	600 V
MPPT Voltage Range	200 V ~ 830 V
Number of MPPT	3
Max. Input Current of Each MPPT	35 A / 35 A / 35 A
Output Voltage Range	700 V ~ 830 V
Rated Output Voltage	700 V
Rated Output Current	65 A
Max. Output Current	75 A
Weight	25 kg

ATS Parameters (Optional)



ATS Built-In Bypass

Item	Data
Max. Input Power	100 kVA (Grid & Load)
Rated Grid Voltage	3L / N / PE 400VAC±15%
Grid Frequency	50 / 60 Hz
Switching Time	30ms (Backup)
Cooling	Forced Air-Cooling
Noise	<70dB
Dimensions (W x D x H)	440 x 205 x 920 mm
IP Protection	IP54
Weight	32 kg

Model	STORION-H30	STORION-H30-O
System Technical Specifications		
DC Data		
Battery Type	LiFePO4	
Depth of Discharge (DoD)	90% (On-Grid), 85% (Off-Grid)	
Battery Voltage Range	150 V ~ 750 V (350 V ~ 750 V@full load)	
Battery Energy Range	34.56 kWh ~ 96.77 kWh	
Standard Battery Cluster	1	
PV Voltage Range	250 V ~ 830 V	
MPPT Voltage Range	200 V ~ 830 V	
Number of MPPT	3	
Number of Strings for Each MPPT	2	
Max. Input Current of Each MPPT	35 A	
AC Data (Grid)		
Rated Power	30 kW	
Max. Input Power	60 kW	
Rated Grid Voltage	3L / N / PE 400VAC±15%	
Grid Frequency	50 / 60Hz	
Rated Current	42 A	
Output THDi	<3%	
AC PF	Listed: 0.8 ~ 1 leading or lagging; Actual: 0.1 ~ 1 leading or lagging	
Peak Efficiency	97.30%	
AC Data (Backup)		
Rated Output Power	30 kW	
Rated Output Voltage	3L / N / PE 400VAC±20%	
Frequency	50 / 60 Hz	
Overload Capacity	110% ~ 120%, 10min; 120% ~ 150%, 200ms	
General Data		
Dimensions (L x W x H)	1100 x 900 x 2000 mm	1200 x 900 x 2160 mm
Weight of the Whole System	<1.4T (Full Battery)	<1.6T (Full Battery)
Protection Level	IP20	IP54
Operating Temperature Range	20 ~ 30°C	- 40 ~ 50°C
Relative Humidity	0 ~ 95% (Non-Condensing)	
Max. Working Altitude	3000 m / 9842 ft	
Warranty	3 Years Product Warranty	
Cooling	Forced Air-Cooling	HVAC
Communication Interfaces	RS485, CAN, TCP, Ethernet	
Fire Protection	Smoke Temperature Composite Detector	Aerosol Fire Protection
Certifications	EN62109, EN62477, IEC61000, UKCA, VDE4105, Tor R25, EN0549, G99, VDE4110	

*8 x M38210-SC Ratsd Power 27.6kW



"BIGGER & STRONGER"

Commercial & Industrial Solution Supports Your Business

AlphaESS is a world-leading energy storage solution and service provider covering the full power range.

 @AlphaEnergyStorageSystem  @AlphaESS  @alpha_ess  @AlphaESS  www.alphaess.com

Alpha ESS Co., Ltd.

Tel: +86 513 8060 6891
Email: info@alpha-ess.com
Website: www.alphaess.com
Add: Jiuhua Road 888, Nantong High-Tech Industrial Development Zone, Nantong, Jiangsu Province, China

Alpha ESS Suzhou Co., Ltd.

Tel: +86 512 6828 7609
Email: info@alpha-ess.com
Website: www.alphaess.com
Add: Building 10-A, Canal Town Industrial Park, 99 Taihu E Rd, Wuzhong District, Suzhou, Jiangsu Province, China

Alpha ESS Shenzhen Co., Ltd.

Tel: +86 0755 2850 3653
Email: service.pps@alpha-ess.com
Website: www.alphaess.com
Add: Bantian Xinghe WORLD B 1302, No. 1 Yabao Rd, Bantian Street, Longgang District, Shenzhen, Guangdong Province, China

Alpha ESS Australia Pty. Ltd.

Tel: +61 02 9000 7676
Email: Australia@alpha-ess.com
Website: www.alphaess.com
Add: 8/15-21 Gibbes Street, Chatswood, NSW 2067 Australia

Alpha ESS Europe GmbH

Tel: +49 6103 4591 601
Email: europe@alpha-ess.de
Website: www.alpha-ess.de
Add: Paul-Ehrlich-Straße 1a, Langen, Hessen D-63225 Germany

Alpha ESS Italy S.r.l.

Tel: +39 339 462 4288
Email: info@alpha-ess.it
Add: Via Don Minzoni, 17, Calenzano Firenze 50041 Italy

Alpha ESS International Pte. Ltd.

Tel: +65 6513 1125 / +65 6513 1126
Email: Singapore@alpha-ess.com
Add: 2 Corporation Road #01-06A Corporation Place 618494 Singapore

Alpha ESS UK Ltd.

Tel: +44 145 354 5222
Email: info@alpha-ess.com
Add: Drake house, Long street, Dursley, gl11 4hh UK

Alpha ESS Korea Co., Ltd.

Email: info@alpha-ess.com
Add: 2F, 19-4, Nohyeong 11-gil, Jeju-si, Jeju-do, Republic of Korea

Alpha ESS USA, Inc.

Tel: +1 408 368 7828
Email: usa@alpha-ess.com
Add: Unit 5 2180 S Ivanhoe St, Denver, CO 80222 USA